

Crathco® Visual Granita Machine

Operation and Instruction Manual for G & MG Series Models

TABLE OF CONTENTS

Introduction and Warnings.....	2
Installation.....	2-3
Connection To Power Supply.....	3
Preparing Product	4
Operating Panel.....	4
Programming - G Series Electronic Touchpad Model	4-6
Errors - G Series Electronic Touchpad Model	6-7
Operating Panel Description-MG Series Traditional Rocker Switch Model	7
Dispensing Product	8
Adjustments	8
Cleaning & Sanitizing	9-11
Maintenance	11-13
Crathco Granita Preventive Maintenance Checklist	14-15
Accessories	16
Troubleshooting	17-18
Exploded View	19-26
Crathco Granita G&MG Series Parts List	27
Gear Motor Exploded View	28
Refrigeration Diagrams.....	29-30
Electrical Diagrams.....	31-33

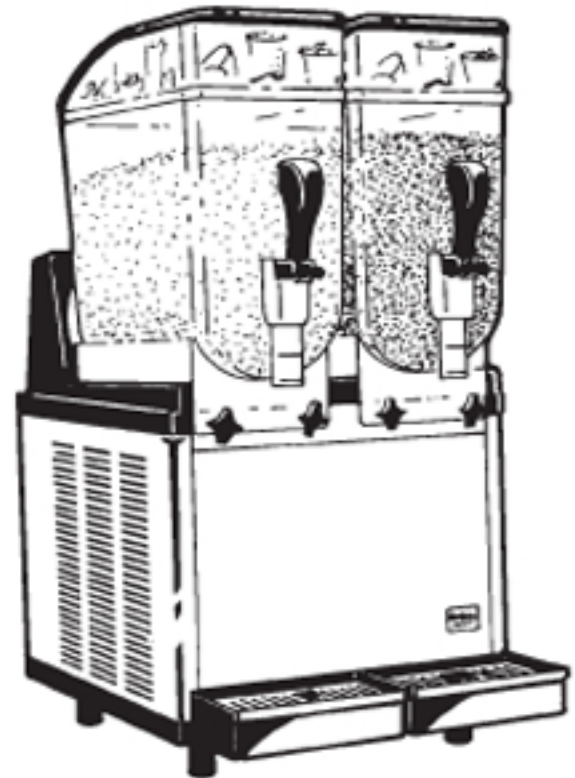

Models G23-2B, G235-2B, G236-2B,
MG23-2B, MG235-2B & MG236-2B

*Prior authorization must be obtained
from Grindmaster Corporation
for all warranty claims.*



Frozen Beverage Dispensers

Formerly Witch

Parts and Service

www.frozendrinkmadness.com

972-276-2757, Fax 972-423-9993

Randy@frozendrinkmadness.com

www.MargaritaMachineParts.Net

Introduction and Warnings

This instruction manual is an important part of this Granita machine and must be kept for future reference.

Carefully read the warnings contained in this instruction manual before installing and operating this Granita machine.

Instructions For Machine Transport

NOTE: Refrigeration equipment must remain upright to avoid damage to the compressor

In order to prevent the oil contained in the compressor from flowing into the cooling circuit, it is necessary to always ship, carry, store and handle this Granita machine in an upright position, following the instructions located on the packaging. Never ship, carry, store or handle unit on its side.

Installation

- 1.) Cut banding straps from box and lift the box off the machine (see fig. A).
- 2.) Positioning the machine
 - The machine must be well ventilated. Leave an 8" (20 cm) clearance on the sides and back of the machine to allow proper ventilation. Installation of the machine near a heat source should be avoided. Some heat sources you should avoid locating this unit too close to are ovens, coffee machines, cold or frozen beverage dispensers or ice machines (equipment with compressors that expel hot air through its vents). Machines should also not be positioned near dust producing units such as a Powdered Cappuccino or Cocoa dispenser. A room temperature between 59°F (15°C) and 77°F (25°C) is recommended (see fig. B).
 - The lit merchandising covers are reversible (front to back) depending upon the needs of the operator (see fig. B).
- 3.) Remove Shipping Pin

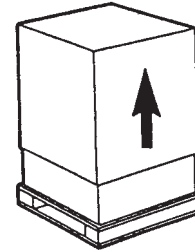

(Figure A)

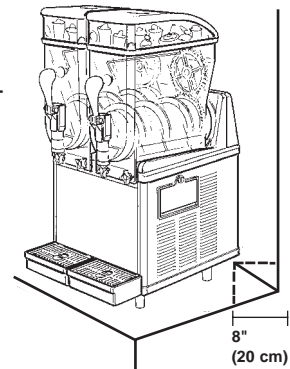

(Figure B)



Attention: Shipping pin attached to tag located behind each bowl must be removed before starting machines.

- Lift up and remove rear back-lit merchandiser panel (see fig. C). NOTE: Some units may have dual rear back-lit merchandiser panels, these function in the same manner as the single panel rear merchandisers.
- Pull out each pin attached to each tag (see fig. D)
- Replace rear back-lit merchandiser panel (see fig. E).

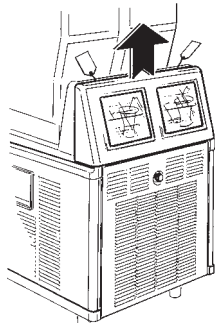

(Figure C)

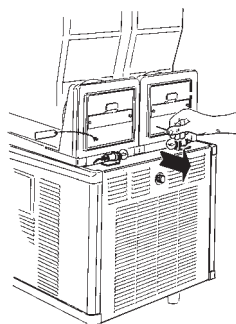

(Figure D)

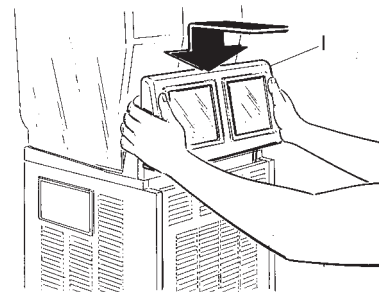

(Figure E)

Installation (cont.)

4.) Installing the Top Lid Merchandiser (requires Phillips head screwdriver)

- Unplug the cord to the lid and remove the lid from the machine.
- On top of the cover, remove the 4 hole plugs over the front (2) screws, middle (near rocker switch) and back screws then remove these 4 screws with a Phillips head screwdriver. Remove the black top part of the cover from the clear plastic base. (see fig. E)
- Slide the merchandiser header around the outside edge of the lid's clear plastic base. Position bottom edge of header in grooved area. (see fig. F)
- Reassemble the black top cover onto the clear plastic base. The top edge of header should slide into black top cover grooved area. (see fig. F) Replace screws. Replace hole plugs (the angled plugs goes in the rear hole, and the two large plugs go in the two front holes and the small plug goes in the center hole by the rocker switches).
- Replace assembled lid on machine and reattach cord.

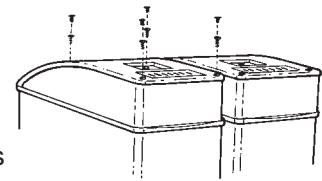

(Figure E)

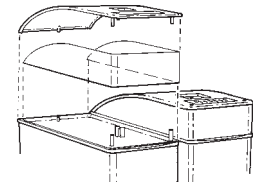

(Figure F)

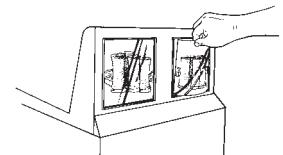

(Figure G)

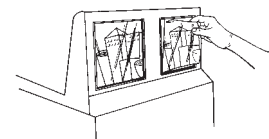

(Figure H)

5. Installing the Rear Back-lit Merchandiser

- To remove any existing artwork, bend or pinch the middle of the back-lit merchandiser and pull it from the rear merchandising display casing. (see fig. G)
- To insert new art, slide the left corner edges into the left top and bottom casing edges. (see fig. H)
- Slightly bend art and insert the right side of art into the right top and bottom casing edges. (see fig. H)
- Smooth out art until all edges are properly inserted into the casing.

Connection To Main Power Supply



Attention: Before inserting the plug into the electrical outlet, carefully read the following precautions.

- The electrical safety of this Granita machine can only be achieved if the machine is properly connected to an appropriate grounded, electrical receptacle that is in compliance with current national safety standards. Therefore, the manufacturer cannot be held responsible for damage and/or injury caused by failure to connect the unit to an appropriate source of power.
- For a safe and correct installation, connect the unit to a dedicated outlet.
- Do not alter the cord or plug in any way.



Attention: Altering the cord or plug will void the warranty.

- The entire length of the power supply cord must not, in any way, be compressed (bent or bunched together) nor may extension cords be used.
- Do not obstruct the ventilation and heat dispersion grill vents on the side and rear panels of the unit. An insufficient ventilation process may reduce the efficiency of the machine, causing it to function inadequately, and cause serious damage to the machine. A minimum of eight inches (20cm) clearance is necessary on each side and behind the unit.

Preparing Product

Attention: Make sure that the mixture has a 13% minimum Brix (sugar content). A lower concentrate could seriously damage the mixing parts, as well as the gear motors. **NEVER USE ONLY WATER.**

- 1.) If using product concentrate (instead of ready-to-use product), dilute and mix the product with water, according to the directions given by the manufacturer, in a separate container (see fig. I). Never pour dry powder, crystals, or concentrate into a dry bowl.
- 2.) Slide the merchandising lid either forward or toward the back of the bowl until the “stops” reach the edge of the bowl. (It is not necessary to remove the merchandising cover.) When sliding lid back make sure that no droplets of water come off lid. Pour the prepared product into the bowl (see fig. J). Do not spill any material on lid or on bowl. There is a minimum and maximum fill line on the bowl. Do not overfill or run the unit without enough product. Running unit with product below the minimum full line may cause damage to the unit.
- 3.) Insert the plug into a dedicated electrical outlet.



(Figure I)

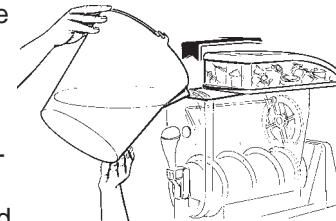

(Figure J)

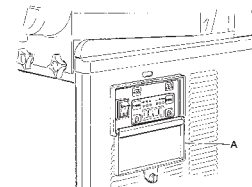

(Figure K)

Operating Panel

In order to access the operating panel, lower the cover (A) as shown in figure K. To lower the cover use a coin or other object to turn the keyless lock to the horizontal position.

Operating Panel -Electronic Touchpad

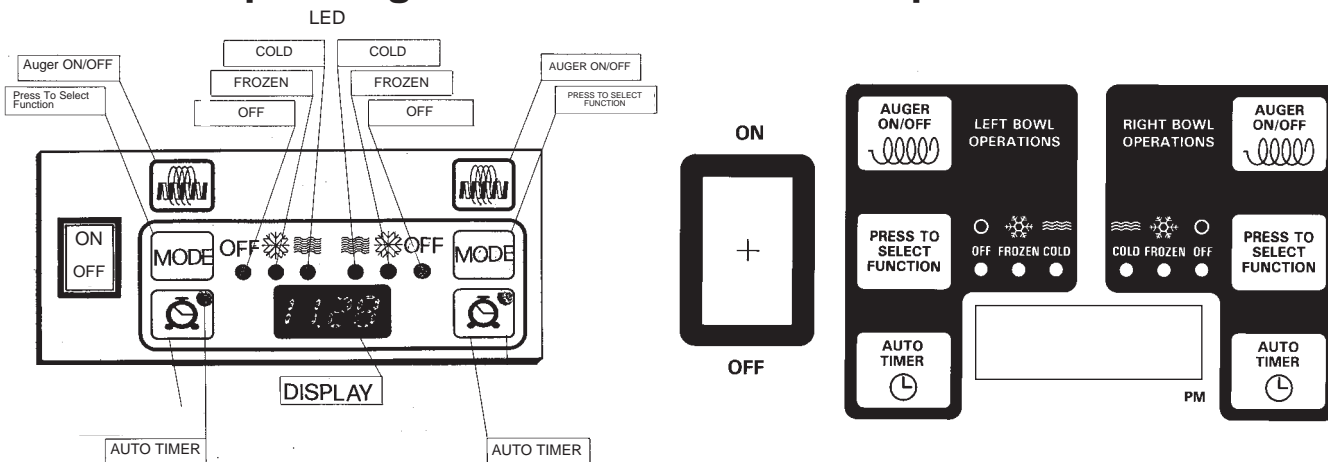

(Figure L)

Programming G Series Electronic Touchpad Models

Models G23-2B, G235-2B & G236-2B Electronic Touchpad:

Main Power Switch:

- 1.) Turns unit ON.
- 2.) Selects 12/24 time or FP/CP temperature display when turned ON while simultaneously depressing the auger button.
- 3.) Sets current time when turned ON while simultaneously depressing the “Mode/Press To Select Function” button.

Model G23-2B Electronic Touchpad (cont.):

Auger ON/OFF Button:

- 1.) Turns auger ON and OFF when main power switch is ON.
- 2.) Must be ON to permit defrost time to be reset.
- 3.) Must be ON to activate the “Mode/Press To Select Function” button to select manual “OFF”, “FREEZE” or “COOLING” functions.

Mode/Press To Select Function Button:

- 1.) Used to manually select “OFF”, “FREEZE” or “COOLING” functions when auger is turned ON.
- 2.) Accesses defrost timer reset mode when depressed for an extended period when auger is turned ON.
- 3.) Locks in hours, minutes and final time settings after they are reset using the “Auto Timer” button.
- 4.) Does not function when light on “Auto Timer” button is illuminated.

“Auto Timer” button

- 1.) Turns auto defrost mode ON or OFF (light on switch indicates when auto defrost mode is activated).
- 2.) Used to adjust the hours and minutes settings when readjusting current time or auto defrost timer.

Enter Time Programming on Initial Installation or in the Event of a Time Change:

- 1.) Turn OFF power switch.
- 2.) While pressing left “Press To Select Function” button, turn ON power switch while continuing to hold the “Press To Select Function” button until the display illuminates (hour digits will start to blink).
- 3.) First set hour by pressing the “Auto Timer” clock button until the appropriate hour is shown (note: when using a 12 hour clock the time is P.M. when the dot at the bottom right corner of the LED is lit; when dot is not lit it is A.M.)
- 4.) To set the minutes press the left “Press To Select Function” button, then press the “Auto Timer” clock button until the appropriate minutes are set.
- 5.) To save your settings press the “Press To Select Function” button one more time.

Setting Defrost Timer (Night Setting):

- 1.) Turn power switch ON.
- 2.) Then press “Auger ON/OFF” button on for the side you are setting.
- 3.) Then press and hold the “Press To Select Function” button until you hear a long beep and the LED, “cold” and the “Auto Timer” clock light begins to blink.
- 4.) Press the “Auto Timer” clock button to set the hour you want it to turn to refrigeration mode and then press the “Press To Select Function” button to save the setting.

Setting Defrost Timer (Night Setting) (cont.):

- 5.) Then press the “Auto Timer” clock button to set the minutes to complete time setting that you want it to turn to refrigeration mode, (defrost mode). Then press the “Press To Select Function” button to save the setting.
- 6.) Proceed to setting the time you want the machine to turn to freezing mode by following steps 4 and above. Then press the “Press To Select Function” button to save the time settings for freeze mode. Freeze light should be blinking.

Note: Once the settings have been saved, the unit will save the settings, even when the power switch is turned OFF.

When the light on the “Auto Timer” clock button is “on”, the defrost timer is activated. To turn OFF the defrost timer, press the “Auto Timer” clock button(s) until the light(s) on the clock button(s) turns off.

Operate in Automatic Mode (with Defrost Timer Activated):

- 1.) Turn power switch ON and wait for LED to light up.
- 2.) Press auger button “ON” for the side you are setting.
- 3.) To operate in defrost mode press the “Auto Timer” button until it is illuminated.
- 4.) When setting automatic times, please keep in mind it will take time for the frozen product to become liquid or vice versa.

Operate in Manual Mode (without Defrost Timer Activated):

- 1.) Turn power switch ON and wait for LED to light up.
- 2.) Make sure clock button is OFF (LED light on clock button should not be lit up).
- 3.) First turn auger on by pressing “Auger ON/OFF” button until it beeps. (Note: The auger must be on before unit will allow the cooling or freezing mode to activate)
- 4.) Then select refrigeration or freezing mode by pressing the “Press To Select Function” button until the light under the selection you desire is lit up. (Note: In the cooling mode, the LED will read the actual temperature of the product {The temperature setting is preset to NSF standards and is not adjustable.}) In the freezing mode the LED will read the current time.

G SERIES MODELS - ERROR MESSAGES

1.) “FILTER CLEANING” ALARM

A filter cleaning alarm will activate when the unit is running hot due to insufficient internal air circulation. When this occurs a “Filtr” message will appear on the touchpad LED readout and an intermittent audible tone will also sound to alert the operator of this condition.

The “Filtr” message will appear when the alarm activates (a beeping sound every 4-5 seconds). To determine the condition that caused the alarm and correct problem, see list of conditions below:

- Condition: The filter is dirty and needs to be cleaned. - Corrective Action: Clean and replace filter following instructions on page 11 (Removing and Cleaning Filter).
- Condition: The unit is positioned too close to a wall or other object restricting air flow and causing the machine to run at a higher temperature. - Corrective Action: Reposition unit to maximize ventilation space (see page 2 - installation figures).
- Condition: The filter is not properly installed. - Corrective Action: Properly install filter see “Removing and cleaning filter” page 11.
- Condition: The unit has been installed near a heat source, such as a coffee machine, ice maker or cold beverage machine which expels hot air from its vents, causing the machine to run at a high temperature. (Installation near a heat source should be avoided) - Corrective Action: Reposition unit to maximize ventilation space (see page 2 - installation figures).



G SERIES MODELS - ERROR MESSAGES (CONT.)

2.) "SYSTEM OVER TEMPERATURE" ALARM

- A system over temperature alarm will activate as a safety when the unit has overheated to protect the compressor.
- The system automatically goes to "OFF" status where the compressor's operations is stopped, while augers will keep working to avoid forming ice blocks.
- When this occurs an "Err" message will appear on the touch pad LED readout accompanied by a continuous buzzer sound to alert the operator of this condition.
- When this alarm activates, turn off all switches. Then determine the condition. (See "Filter Cleaning" Alarm Section for Conditions and Corrective Actions)

Operating Panel Description-MG Series Traditional Rocker Switch Model

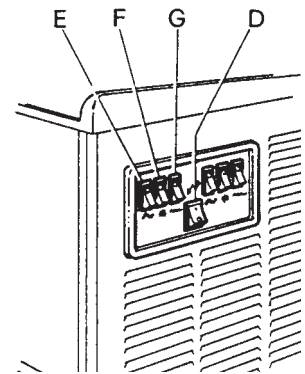

- 1.) Turn ON the main power switch  (D) (see figure M)
- 2.) Description of the buttons (see figure cc):
Each bowl is controlled by three switches which have the following functions:

-  (E) activates the mixing parts/spiral auger
-  (F) activates the freezing of the product
-  (G) activates the refrigeration of the product (night/defrost setting)





(Figure M)

To obtain a slush:



Select the  (E) switch to activate the mixing parts/spiral auger and select the  (F) switch to activate the freeze mode.

Note: There is a 4 minute delay before the compressor will start.

To obtain cold (night/defrost) drinks:

Select the  (E) switch to activate the mixing parts/spiral auger and select the  (G) switch to activate the refrigeration mode.

Stand-by mode setting:

Select the  (E) switch to activate the mixing parts/spiral auger and the  (G) switch to activate refrigeration mode to keep the product(s) in bowl(s) overnight.

Defrost Timer Operating Instructions

- 1.) SETTING CURRENT TIME - Rotate the program disc, in the direction of the arrows, to align the correct time of day with the time of day mark. Figure H shows the timesetting of 7:00.
- 2.) SETTING DEFROST MODE - Set the defrost period by pushing the switch actuator toward the outer edge of the program disc. Freeze time is set by pushing the switch actuators toward the center of the time switch. Figure N shows a defrost time from 11:00 to 6:15. The light and dark shaded areas of the program disc indicate day and night respectively. Each actuator is equivalent to 15 minutes.
- 3) All switches (power, auger, refrigeration and freeze) must be "on" for defrost timer to properly function.

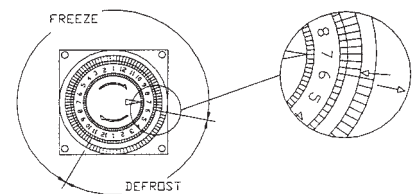

(Figure N)

NOTE: The timer is battery backed. Do not remove power from the unit for greater than 2 weeks as doing so will result in failure of the battery back-up feature. The battery is nickel cadmium and will last from 6 to 8 years if properly charged. The battery is not replaceable upon failure.

Dispensing Product

To dispense the product, position the cup under the dispensing valve (C) and lower the dispensing lever (B) (see fig. O).



Attention: If the machine is turned off at night, with the bowls filled, or just partially filled, a layer of solid ice may form on the surface due to the natural separation of the unmixed (non-moving) product. In this case, before turning the machine back on, remove the layer of superficial ice to prevent damage to the mixing auger.

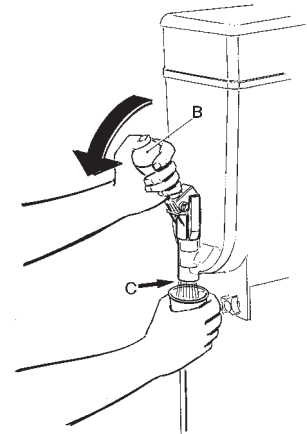

(Figure O)

Adjustments



Attention: To prevent the product from becoming too thick, it is necessary to push left “Press To Select Function” and right “Press To Select Function” keys to cold drink position or to refill the bowl when the level of the granita inside the bowl is below the minimum fill line.

Consistency Adjustment

- 1.) Unplug the machine.
- 2.) Be sure that product in bowl is within proper fill range. (Above the minimum fill line)
- 3.) Remove merchandiser.
- 4.) Change the thickness of the product by turning the screw (D) on the back of the bowl, as shown on fig. P. Turn the screw clockwise for thinner product or counterclockwise for thicker product. The indicator gauge (D1), located on the back of the bowl, shows the degree of adjustment (+/-). (+) = thicker, (-) = thinner
Note: This (D1) is an indicator gauge only. To adjust consistency, turn screw on top (D).

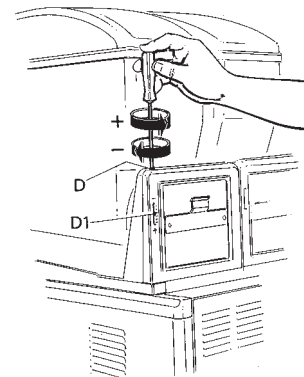

(Figure P)

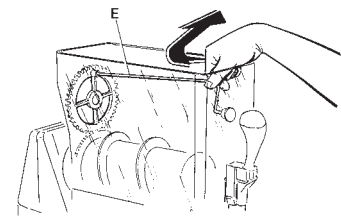





(Figure Q)

Cleaning and Sanitizing Procedures

Warning Disconnect the unit from its power supply prior to cleaning or sanitizing the unit. Failure to do so may result in electric shock.

Daily Cleaning

For the machine to function properly, it is important that the cleaning procedures be carried out daily, according to the following instructions:

- 1.) Turn off the  /  (G, fig. M) refrigeration and  /  (F, fig. M) freezing switches and empty the bowl of its remaining product; after draining the product from the unit, you can fill the bowl with hot water (not boiling) to help melt off any sugar deposits. Then drain the water prior to proceeding to step (2).
- 2.) Unplug the unit.
- 3) Pull out the mixing rod (E) by pushing it slightly backwards to remove it from its position (see fig. Q on pg.8).
- 4.) Unscrew and remove the two knobs (F) then lower the bowl to drain out any remaining product through the dispensing valve (see fig. R).
- 5.) Remove and disassemble the dispensing valve:
 - Remove the pin (G) as shown (see fig. S). Then, remove the handle (B) sliding it from its seat.
 - Simultaneously apply pressure to the two securing tabs (H) and lift the dispensing valve (C) to pull it out of its position (see fig. T).
- 6.) Remove the bowl (L) by unscrewing the two knobs (F) and pulling it downwards as shown in fig. U.
- 7.) Unscrew the securing bolt (M) clockwise. Pull off the auger (N) and remove the shaft seal (O) and the bowl seal (P) (see fig. V).
- 8.) Remove the drain tray by lifting up on the front edge, while lowering the rear edge, and then lift it off the unit (see fig. W).
- 9.) Thoroughly wash each part that has been removed in steps 1-8 and the base (Q), as well as the freezing cylinder (R) with warm water and mild dish-washing detergent. Rinse well with clear water and allow to air dry (see fig. X). Avoid the use of abrasive cleaners which can damage the finish. Do not put in dishwasher. Dishwasher may damage some parts such as the clear plastic auger gears and top mixing bar. Reassemble with clean hands.

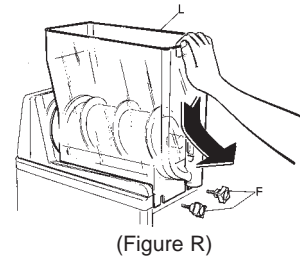

(Figure R)

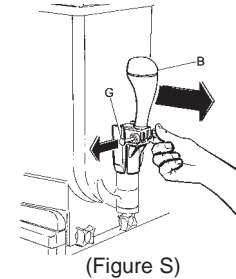

(Figure S)

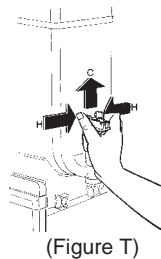

(Figure T)

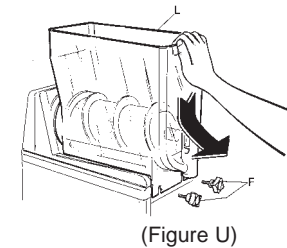

(Figure U)

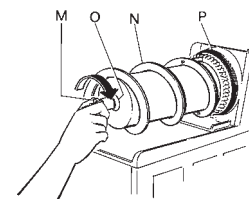

(Figure V)

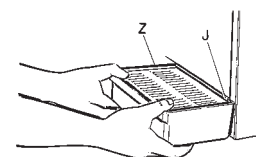

(Figure W)

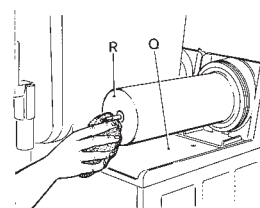

(Figure X)

Cleaning and Sanitizing Procedures (con't)

10.) Reassemble the mixing unit back together, according to the following procedures (see fig. Y):

- Moisten the bowl seal (P) with water and slip it into place at the back of cylinder with ribs angled toward back of freezer.
- Apply food grade lubricant to the inside of the shaft seal (O) and put the shaft seal (O) back on with the flared end of seal toward back of freezer.
- Put the auger assembly (N) back on the evaporator.
- Secure all the parts in place by screwing on the bolt (M) counterclockwise.

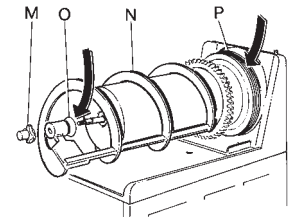

(Figure Y)

11.) Reassemble the bowl (L), positioning it into place. Make sure that the bowl fits tightly to the bowl seal (see fig. Z). We also suggest that the rear part of the bowl be moistened with water or lightly lubricated at the point where it fits together with the seal to make it easier to install bowl.

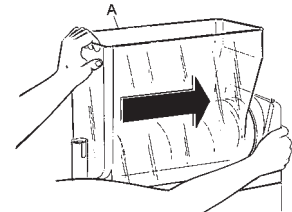

(Figure Z)

11a.) The lower right and left bowl flanges should fit on the outside of each black triangle edge (see fig. AA). **The lid cover will not fit properly if this is not correctly positioned.**

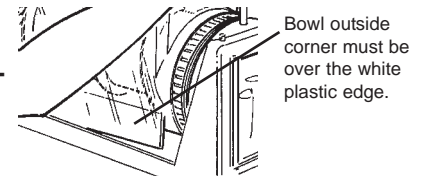

(Figure AA)

12.) Secure the bowl (L) by keeping it lifted until the bolt (M) is aligned with its hole (S), then tightly screw on the knobs (F) without exerting excessive pressure to avoid cracking the bowl (see fig. BB).

13.) Reassemble the mixing rod (O) so that its gears are aligned with the lower gear ring. This will allow the front pin to fit perfectly in its position on the bowl (see fig. CC).

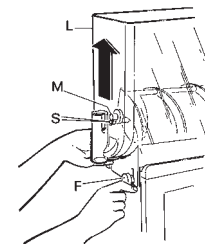

(Figure BB)

14.) Reassemble in sequence the parts of the dispensing valve as follows (see fig. DD).

- Make sure that the dispensing valve seat is properly lubricated with food-grade lubricant (such as Haynes Lubrifilm).
- Put the dispensing valve body (T) in its seat.
- Insert the spring (U).
- Put the dispensing valve upper body (V) into its position until it completely snaps into place.
- Reassemble the handle (B) and insert retaining pin (G) following the same procedures in #5, fig. S.

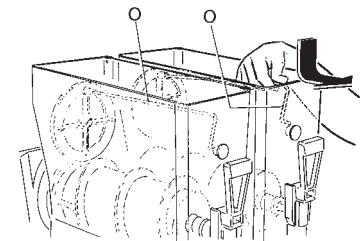

(Figure CC)

15.) Reinstall the drain tray (fig. T). Make sure that the condensation drainage tube (J) is reinserted into its correct fixed position, allowing it to drain into the tray.

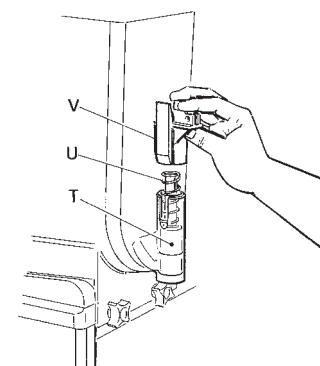

(Figure DD)

Cleaning and Sanitizing Procedures (con't)

- 16.) Plug the unit back into appropriate power supply.
- 17.) After the cleaning and reassembly of the mixing parts and bowl as per above instructions, fill the bowl with a mix of water and an approved cleaning solution (example kay5), according to the measures specified.
- 18.) Start the mixing part of the machine for about 10 minutes to sanitize all parts. Follow the cleaning solution specifications.
- 19.) Drain the cleaning solution as follows:
 - Unscrew the two knobs (F) see fig. U);
 - then lower the bowl to drain out any remaining product through the dispensing valve (C) (as shown in fig. U).
- 20.) Screw again the knobs (F) to fix the bowls.
- 21.) With a clean cloth wash the underside of the lamp cover with warm water and a mild detergent. Allow this part to air dry and then wipe it with a clean cloth which has been dipped in the sanitizing mixture. Prepare a minimum of 4 gallons (15 liters) of sanitizing solution (Stera Green Label or equivalent) following the manufacturer's instructions.

Note: Add 4 ounces of Stera Sheen to 4 gallons (15 liters) of 120° Fahrenheit (50° Centigrade) water to achieve a concentrate of 100 parts per million.



Warning: Lamp cover must be unplugged. Electric shock could occur if cover or power cord come in contact with solution.

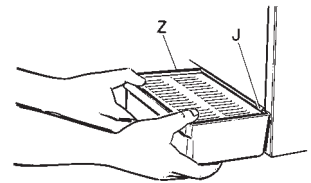

(Figure EE)

Maintenance



Warning: Disconnect the unit from its power supply prior to performing any maintenance procedures. Failure to do so could result in electric shock, injury from hazardous moving parts or serious burns from hot surfaces.

Removing and cleaning the filter (Weekly)

This should be done weekly or more often if necessary.

In order to guarantee an efficient refrigerating system, it is essential that the filter be properly cleaned, according to the following procedures:

- 1) Unplug the machine.
- 2) Unscrew the knob (K) in order to remove back panel (see fig. FF).
- 3) Remove the filter (W) held inside the back panel (X) and clean it properly using water or vacuum (see fig. GG).
- 4) Place the cleaned filter back inside back panel and reinstall the back panel on the machine by screwing in the knob (K).

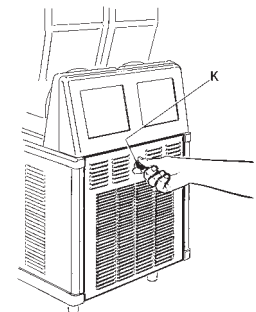

(Figure FF)

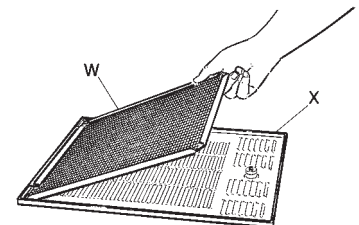

(Figure GG)



Attention: Failure to maintain a clean filter and condenser will cause damage to the unit not covered by warranty.

Maintenance (con't)

Cleaning the Condenser (Monthly)

This cleaning should be done monthly or more often if necessary.

In order to guarantee an efficient refrigerating system, it is essential that the condenser be properly cleaned at regular intervals, according to the following procedures:

- Unplug the machine.
- Remove the back panel and filter. Using a dry brush or vacuum, remove the dust that has accumulated between the fins of the condenser (see fig HH).

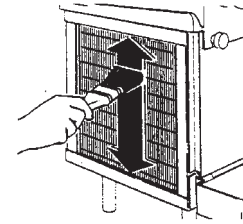

(Figure HH)

Replacing the Lightbulbs (As Needed)

- Unplug the machine.

Lid Lights

- Unplug the cord to the lid and remove the lid from the machine.
- In order to access the lightbulb in the merchandising cover, insert a quarter in the slot on the small panel on the top of the cover (DA) and rotate the quarter to pop the panel open (see fig. II).
- Holding the merchandising cover with the top open, carefully remove the lightbulb (see fig. JJ).
- Insert the new bulb and replace the light cover.
- Place lid on machine and plug lid cord back into lid.



(Figure II)

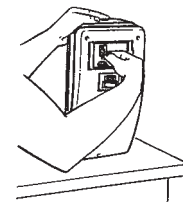

(Figure JJ)

Rear Merchandiser Lights

- In order to access the lightbulb from the rear back-lit merchandiser (BB), remove the rear merchandiser by sliding it upwards (see fig. KK).

NOTE: Some units may have dual rear backlit merchandiser panels, these function in the same manner as the single panel rear merchandisers.

- Then remove the lightbulb(s) (BA) (see fig. LL).
- Insert the new bulb(s) (BA).
- Reassemble the rear back-lit merchandiser (AA) making sure that its slots are inserted properly in the relevant brackets (CA) (see fig. LL).
- Plug machine into dedicated outlet.

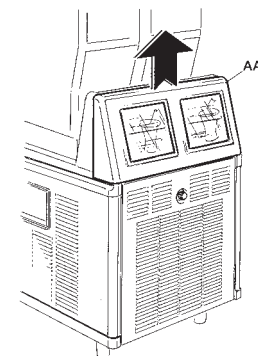

(Figure KK)

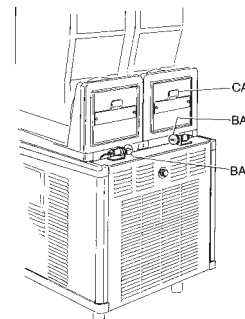

(Figure LL)

Maintenance (con't)

Seal Maintenance

Bell Shaped Seal

- Replace every 1 to 6 months depending on conditions of use and level of maintenance and lubrication. This part should be lubricated during re-assembly after every cleaning.

Spindle Bushing Seal

- Replace every 6 to 12 months depending on conditions of use and level of maintenance. Replacement of spindle bushing should ONLY be done by a qualified service technician.

To Replace Spindle Bushing:

Tools required: Power screwdriver, Rubber mallet, Replacement Kit #90104, spindle bushing extraction tool #90544

Each PM kit # 90104 contains 2 bell shaped shaft seals, 2 spindle bushing seals, 4 dispense valve o-rings, 1 laminated care and cleaning card and one PM checklist.

1. Empty product bowl and disassemble as if for cleaning. Spindle bushing seals should be replaced every 6-12 months and bell-shaped shaft seals should be replaced once every 1-6 months depending on conditions of use and maintenance.

2. Slide the threaded metal cylinder on the drive shaft so that the flat surface meets the face of the evaporator cylinder.

3. Thread the two tapping screws (max length 1 1/8") through the holes in the tool and into the spindle bushing seal. Use of a power screwdriver is suggested. (See Figure MM)

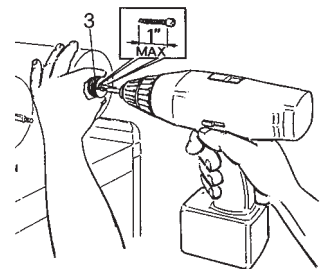

Figure MM

4. Screw the outer cylinder of the extracting tool on to the metal cylinder by rotating clockwise until it is fully connected.

5. Continue turning the outer cylinder clockwise until the spindle bushing seal is removed. If necessary, apply higher torque by inserting a screwdriver in the holes of the outer cylinder. (See Figure NN)

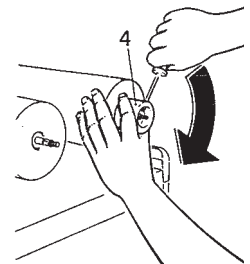

Figure NN

6. After extracting the old spindle bushing seal, position a new one in the evaporator cylinder. The gasket (black side) should be facing the inside of the evaporator.

7. Position the inserting pipe so that its smaller diameter touches the spindle bushing seal.

8. Push the spindle bushing seal in by tapping on the pipe with a rubber mallet. Be sure the spindle bushing seal is completely in place. (See Figure OO)

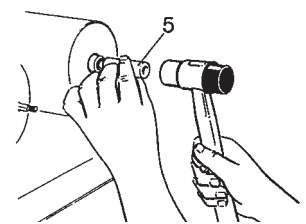

Figure OO

When replacing the spindle bushing be sure to check the condition of the driveshaft. If the surface is not smooth and the driveshaft is not secure, then replace the driveshaft while replacing the spindle bushing. Replacement of a driveshaft should only be done by a qualified service technician using PM kit #90110.

Bowl Gasket (located at rear of bowl)

- Replace as necessary depending on the conditions of use and level of maintenance. This part should be lubricated during re-assembly after every cleaning.

O-Ring Maintenance

- O-rings should be replaced every 6 to 12 months or as necessary where wear is apparent.

Crathco Granita Preventive Maintenance (PM)

Checklist for Kit 90566 -

Serial # 11259 and above

(and units with lower serial #'s that have been converted to stainless steel shafts - units with black stainless shafts will need to be converted using PM Kit # 90110B)

Model # _____
Serial # _____
Date: _____
PM by _____
Of Company _____
Store Name/# _____
Address _____

Store Mgr Name _____
Signature _____

A preventive maintenance visit should be performed every 6 months. In addition, air filter should be cleaned weekly, and every three months the condenser should be cleaned, and the rubber shaped bell shaft seals should be replaced. Failure to complete PM's every 6 months is considered abuse of the machine, and therefore voids the warranty. Proof of PM must be documented with Grindmaster Corporation to maintain warranty coverage. To document your PM, complete this form with signatures, place used/worn parts that were replaced during the PM inside envelope, and mail to Grindmaster Corporation. Parts returned should include 2 evaporator seals, 2 rubber bell shaped shaft seals, valve o-rings and shafts (if applicable). First PM on serial numbers 11259 to 12202 should also include kit number 90225 (one per serial number).

The following procedures should be performed during a Preventative Maintenance visit, using PM kit # 90566 or 90110B.

- Document model and serial number of equipment and record above.
- Check product temperature and consistency for proper setting - adjust if necessary.
- Insure product is being mixed properly and is within specification (check and document brix - most products should be around 13% - refer to product manufacturer's recommendations for exact recommended brix).
Record Brix reading here: Left Bowl _____ Right Bowl _____
- Check for leaks at gaskets, o-rings, front shaft seal, etc.
- Empty product from bowls and disassemble unit completely.
- Clean and sanitize all disassembled parts.
- Clean and sanitize top tray and freezing barrel.
- Clean out condensation tube with sanitizer and long brush.
- Check condition of all panels, bowls, lids - replace if necessary.
- Check mixing rods and augers for wear, check mixing rod bearing for wear - replace if necessary.
- Check for bowl knobs (two per bowl to lock down bowl in front) - replace if necessary.
- Check operation of lights in lid and rear of unit (if equipped) - replace light bulbs if necessary.
- Clean re-usable air filter. Check condition of filter and replace if necessary.
- Clean condenser.
- Check condition of bowl gaskets and replace if necessary.
- Replace all o-rings on dispense valves and lubricate.
- Check drive shaft. Replace if necessary, using PM kit #90110B in place of 90566 above.
- Replace evaporator seal in front of evaporator. (use brass tool, included, to slide seal onto shaft, and use the white tool to tap seal into place. Be sure to lubricate seal with food grade grease first)
- Replace bell shaped rubber shaft seal on front of freezing barrel (generously lubricate inside seal)
- Lubricate parts where appropriate (dispense valve o-rings, inside of shaft seal, inner rim of bowl where it meets with the bowl seal)
- Re-assemble unit and refill with product
- Verify and document defrost timer setting and operation and time of day setting and adjust if necessary.
- Check thermostat setting on MG models. Thermostat setting should be between 1-1/2 and 2.
- Verify compressor operation and freezer controller operation.
- Verify ventilation is adequate (8" on both sides and back)
- Check electrical connections and wiring.
- Check fan operation (1 condenser fan and 2 gear motor fans) and clean fan or blades if necessary.
- Review proper periodic care and cleaning instructions (disassembly, cleaning, sanitizing, lubrication and re-assembly) with store personnel. Review proper product mixing and handling instructions with store personnel. Demonstrate and train store personnel to follow proper procedures (stress importance of store level maintenance such as lubrication and filter cleaning).
- Make sure store personnel have appropriate supplies (lubricant and sanitizer) to care for machine.

Crathco Granita Preventive Maintenance (PM)

Checklist for Kit 90104 -

Serial # 11258 and below*

(If unit has been converted to unhardened stainless shaft system, then use kit #90566 instead.)

Model # _____
Serial # _____
Date: _____
PM by _____
Of Company _____
Store Name/# _____
Address _____

Store Mgr Name _____
Signature _____

A preventive maintenance visit should be performed every 3 months. Failure to complete PM's every 3 months is considered abuse of the machine, and therefore voids the warranty. Proof of PM must be documented with Grindmaster Corporation to maintain warranty coverage. To document your PM, complete this form with signatures, place used/worn parts that were replaced during the PM inside envelope, and mail to Grindmaster Corporation. Parts returned should include 2 spindle bushing evaporator seals, 2 rubber bell shaped shaft seals, valve o-rings and shafts (if applicable).

The following procedures should be performed during a Preventative Maintenance visit, using PM kit # 90104:

- Document model and serial number of equipment and record above.
- Check product temperature and consistency for proper setting - adjust if necessary.
- Insure product is being mixed properly and is within specification (check and document brix - most products should be around 13% - refer to product manufacturer's recommendations for exact recommended brix).
Record Brix reading here: Left Bowl _____ Right Bowl _____
- Check for leaks at gaskets, o-rings, front shaft seal, etc.
- Empty product from bowls.
- Disassemble unit completely.
- Clean and sanitize all disassembled parts.
- Clean and sanitize top tray and freezing barrel.
- Clean out condensation tube with sanitizer and long brush.
- Check condition of all panels, bowls, lids - replace if necessary.
- Check mixing rods and augers for wear, check mixing rod bearing for wear - replace if necessary.
- Check for bowl knobs (two per bowl to lock down bowl in front) - replace if necessary.
- Check operation of lights in lid and rear of unit (if equipped) - replace light bulbs if necessary.
- Clean re-usable air filter if so equipped (standard on G & MG models, optional on ID models). Check condition of filter and replace if necessary.
- Clean condenser.
- Check condition of bowl gasket and replace if necessary.
- Replace all o-rings on dispense valves and lubricate.
- Check drive shaft. If surface is not smooth or the drive shaft is not secure (excessive movement in and out) use PM kit #90110, or 90110B in place of 90104 above.
- Replace spindle bushing seal in front of evaporator using extraction tool.
- Replace bell shaped rubber shaft seal on front of freezing barrel (generously lubricate inside seal)
- Lubricate parts where appropriate (dispense valve o-rings, inside of shaft seal, inner rim of bowl where it meets with the bowl seal)
- Re-assemble unit and refill with product
- Verify and document defrost timer setting and operation and time of day setting and adjust if necessary.
- Check thermostat setting on ID and MG models. Thermostat setting should be between 1-1/2 and 2.
- Verify compressor operation and freezer controller operation.
- Verify ventilation is adequate (8" on both sides and back).
- Check electrical connections and wiring.
- Check fan operation (1 condenser fan and 2 gear motor fans) and clean fan or blades if necessary.
- Review proper periodic care and cleaning instructions (disassembly, cleaning, sanitizing, lubrication and re-assembly) with store personnel. Review proper product mixing and handling instructions with store personnel. Demonstrate and train store personnel to follow proper procedures (stress importance of store level maintenance such as lubrication and filter cleaning).
- Make sure store personnel have appropriate supplies (lubricant and sanitizer) to care for machine.

Accessories (not included)

Security Kit Installation (Part # 3468)

Installing Locking Clip

1. Pinhead must be located on righthand side of valve, as shown.
2. The 0.125" slot, on the locking clip, lines up with the horizontal shelf on the valve body.
3. Insert the locking clips as shown.
4. Attach padlock in hole provided on the locking clip.

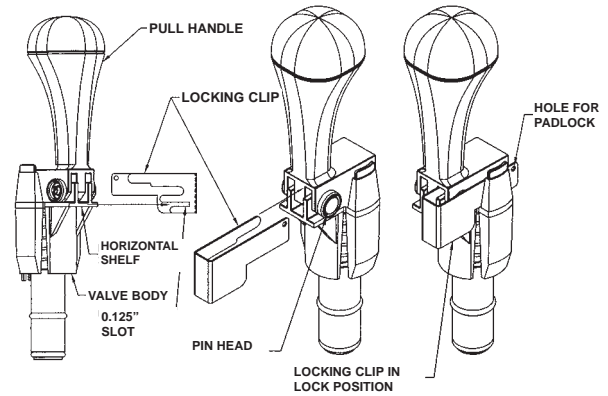

(Figure PP)

Installing Security Straps

1. Hook straps under side edge of the bowl, beginning at the front of the bowl.
2. Slide the straps back on the bowl until they are firmly in place.
3. Interlock straps above the bowl lid.
4. Attach the padlock.

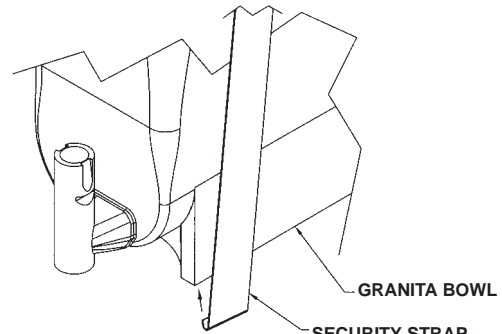

(Figure QQ)

Autofills

Attach liquid autofill systems to your granita dispenser. Autofills minimize manual labor to mix and refill the unit, as well as maintain the product bowl at an attractive level.

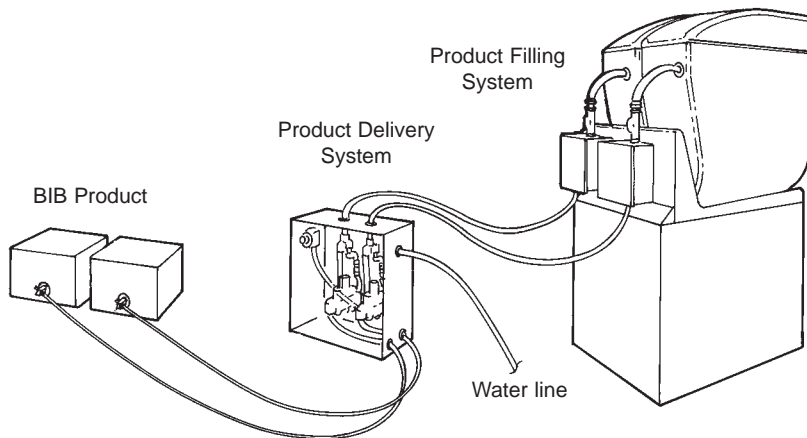

(Figure RR)

Contact your local Grindmaster Corporation representative or Grindmaster Corporation customer service at (800) 695-4500 for more information on any of the above accessories.

Troubleshooting Guide

The following procedures must be performed by a qualified service technician.

Problem	Possible Cause	Solution
<p>The machine does not cool, or cools only partially, but the compressors are running</p>	<ul style="list-style-type: none"> • The space around the machine is inadequate for ventilation • Freezer is in defrost • The condenser fins are clogged with airborne particles • Fan motor is not running • Refrigerant is leaking 	<ul style="list-style-type: none"> • Allow at least 8" (20cm) between the machine and anything next to it; keep away from heat sources • Return to freeze mode • Remove the side panels. Using a brush or compressed air clean the condenser • Check the fan motor's electrical connections and, if disconnected, reconnect. If still not operating, replace the motor • Locate the leak, eliminate it and recharge the system
<p>The machine does not cool or cools only partially, but one or more of the compressors are not running</p>	<ul style="list-style-type: none"> • Electrical components of the compressor(s) are not functioning • Some electrical connections are not complete • One or more of the compressors are malfunctioning • No current is coming to the "compressor delay" PC board 	<ul style="list-style-type: none"> • Replace the malfunctioning components • Check the contacts and correct those that are incomplete • Replace the compressor(s) • Check the electrical connections to the PC board as well as the transformer feeding the PC board and correct
<p>The machine over-freezes, making the auger movement slow or stopped</p>	<ul style="list-style-type: none"> • The product brix is too low • The screw setting for the product consistency control system is set too far toward the "+" position • The limit switch arm is bent away from the gearmotor and prevents contact • The level of the product in the bowl is too low, exposing the auger • The compressor PC board contacts don't open 	<ul style="list-style-type: none"> • Check the product brix and correct • Reset the screw toward the "-" position to produce a thinner consistency product • Using pliers, straighten the limit switch arm • Add more product or turn the refrigeration "Off" • Replace the PC board
<p>The machine is noisy</p>	<ul style="list-style-type: none"> • The fan motor blades are hitting internal components 	<ul style="list-style-type: none"> • Check and correct
<p>The main power switch is "On". The unit is not running.</p>	<ul style="list-style-type: none"> • The fuse(s) are blown • The pressure cutout switch has activated • Some electrical connections are not complete • The main power is not functioning 	<ul style="list-style-type: none"> • Replace the fuse(s) • Clean the condenser or add ventilation space around the machine (the cutout switch reset is automatic when the conditions are corrected) • Check the contacts and correct those that are incomplete • Replace the switch
<p>Product is leaking out of the bowl</p>	<ul style="list-style-type: none"> • One of the bowl seals is not in place 	<ul style="list-style-type: none"> • Replace or reposition the seals

Troubleshooting Guide (cont'd)

Problem	Possible Cause	Solution
Product is leaking from the dispensing valve	<ul style="list-style-type: none"> • The dispensing valve has been incompletely or incorrectly replaced in its position • The free movement of the dispensing valve is impeded • Dispensing valve o-rings are damaged 	<ul style="list-style-type: none"> • Reassemble and replace • Clean and lubricate the valve and valve cylinder with the lubricant provided with the machine • Replace the o-rings
Product is flowing into drain tray through drainage tube	<ul style="list-style-type: none"> • The bell shaped “shaft” seal between the front of the cylinder and the auger hub has not been reinstalled properly • The bell shaped “shaft” seal or the spindle bushing seal is damaged or worn 	<ul style="list-style-type: none"> • Find the seal and put it back in place • Replace the damaged/worn seal and check the condition of the driveshaft.
The auger and/or the upper mixing unit is not turning	<ul style="list-style-type: none"> • Auger not turned on • Some electrical connections are not complete • The gear motor(s) are malfunctioning 	<ul style="list-style-type: none"> • Turn auger on • Check the contacts and correct the ones that are incomplete • Replace the gear motor(s)
The auger and/or the upper mixing units are creating noises as they rotate	<ul style="list-style-type: none"> • The large red bowl seal is not in position, causing the gear teeth not to mesh • The product brix is incorrect • The bell shaped “shaft” seal has been replaced without lubrication or is damaged • The auger has been incompletely or incorrectly reassembled (ie the auger’s gear pins are not properly seated) 	<ul style="list-style-type: none"> • Check and correct • Check the product brix and correct • Replace or Clean and lubricate with the lubricant provided with the machine • Check and correct
There is no light in the merchandising lid or rear merchandising panel	<ul style="list-style-type: none"> • The light bulb is burnt out • The 5 Amp fuse between the transformer and the lamp is blown • The transformer is blown 	<ul style="list-style-type: none"> • Replace (See “Changing the lightbulb” section in this manual) • Replace • Replace
The cover does not fit properly on the bowl	<ul style="list-style-type: none"> • The bowl is incorrectly positioned (the lower, outside corner is not over the lower, outside base piece) 	<ul style="list-style-type: none"> • Remove bowl and position properly
“Filtr” or “Err” message appears on the touchpad LED readout	<ul style="list-style-type: none"> • The filter is dirty and needs to be cleaned • The unit is positioned too close to a wall or other object restricting air flow and causing the machine to run at a higher temperature • The filter is not properly installed • The unit has been installed near a heat source, such as a coffee machine, ice maker or cold beverage machine which expels hot air from its vents, causing the machine to run at a high temperature. (Installation near a heat source should be avoided) 	<ul style="list-style-type: none"> • Clean and replace filter following instructions on page 11 (Removing and Cleaning Filter) • Reposition unit to maximize ventilation space (see page 2 - installation figures) • Properly install filter see “Removing and cleaning filter” page 11 • Reposition unit to maximize ventilation space (see page 2 - installation figures)

If you still need help, call our service department at (800) 568-5715 Ext. 3 (Monday through Friday, 8 am - 6 pm EST) or an authorized service center in your area. Please have the model and serial numbers ready so that accurate information may be given.

Prior authorization must be obtained from Grindmaster Corporation’s Technical Services Department for all warranty claims.

Exploded View MG23-2B (115/60)

(for units up to serial number 8195)

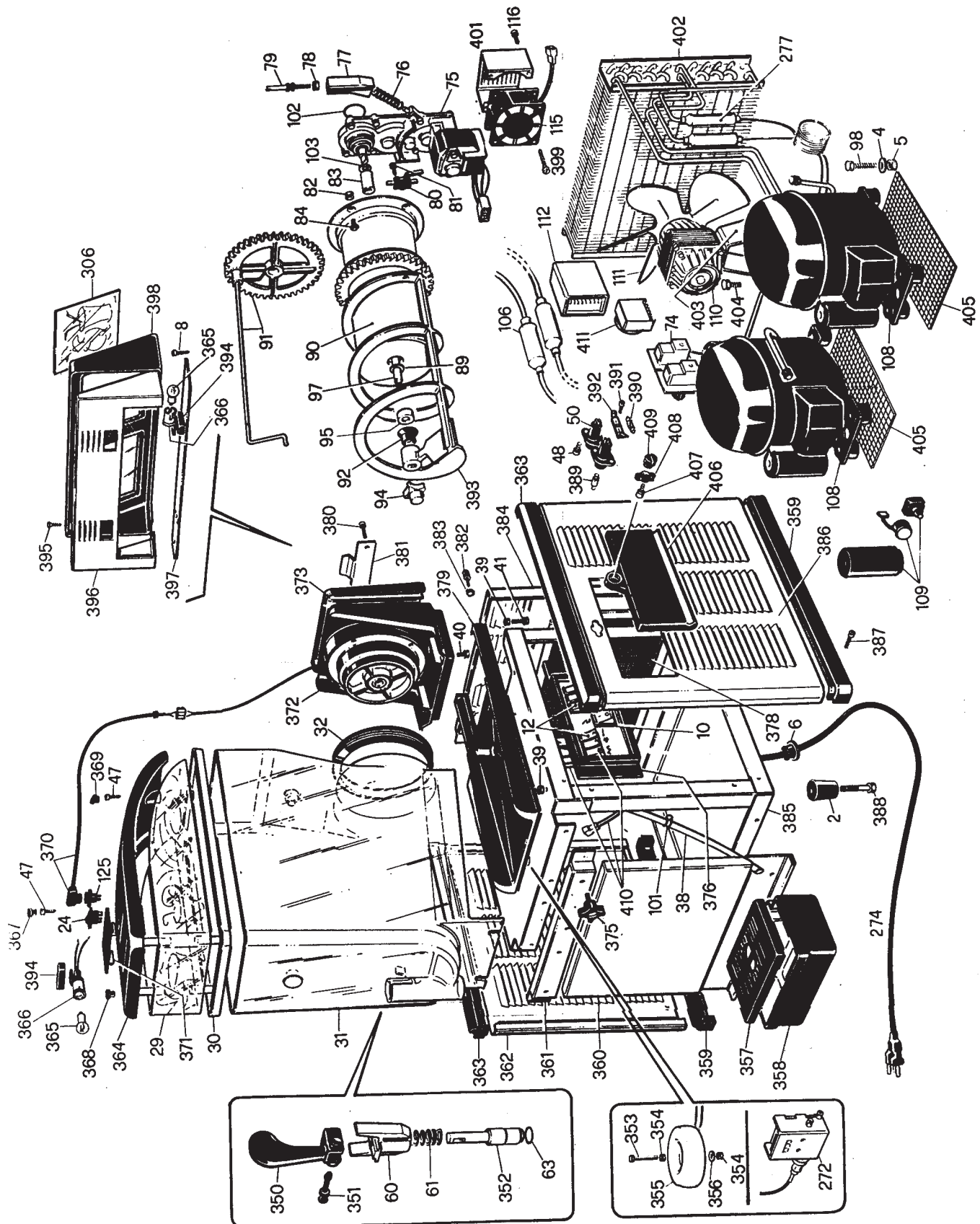

Exploded View G23-2B (115/60)

(for units up to serial number 8195)

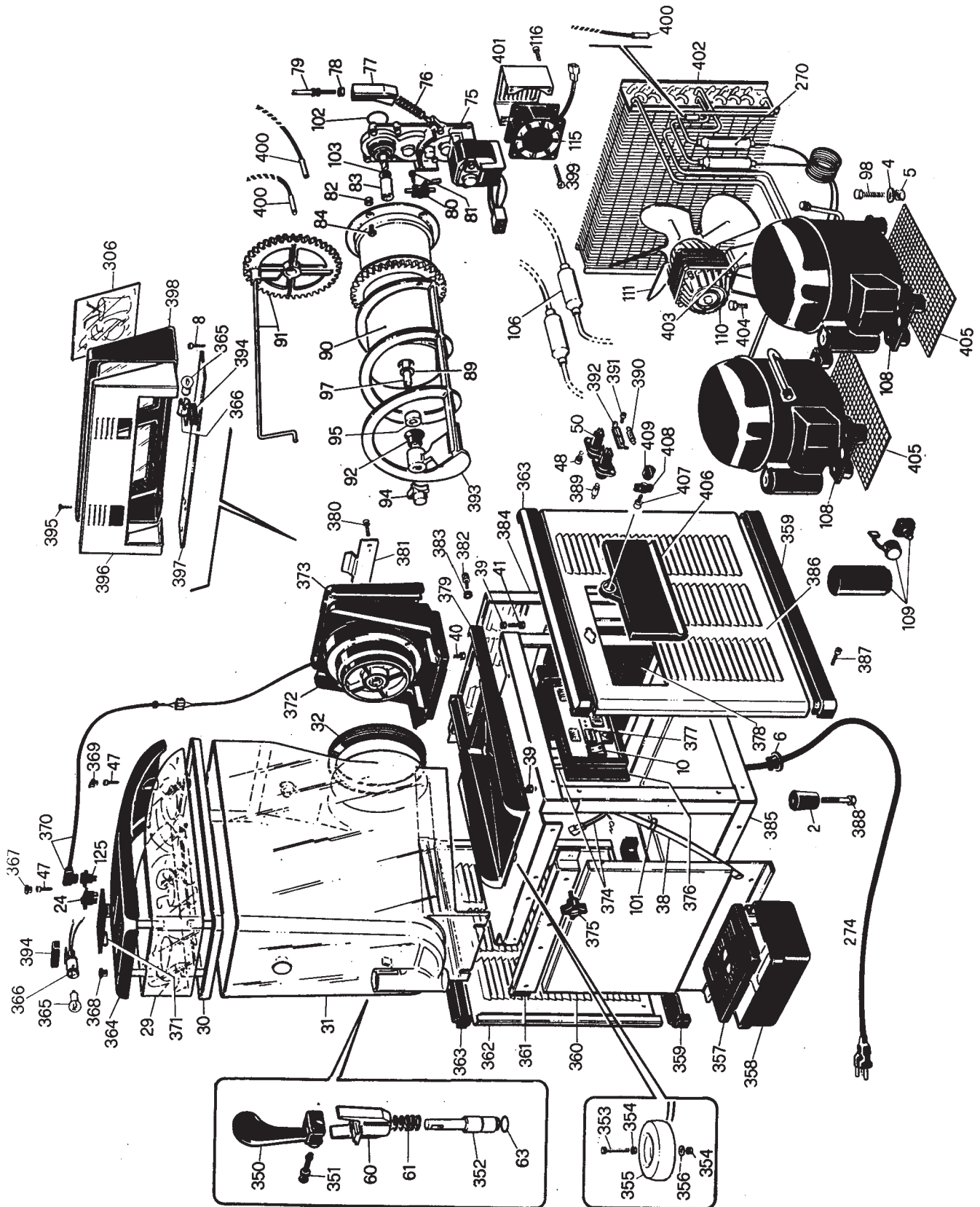

Exploded View G23-2B (115/60) (serial number 8195 and higher)

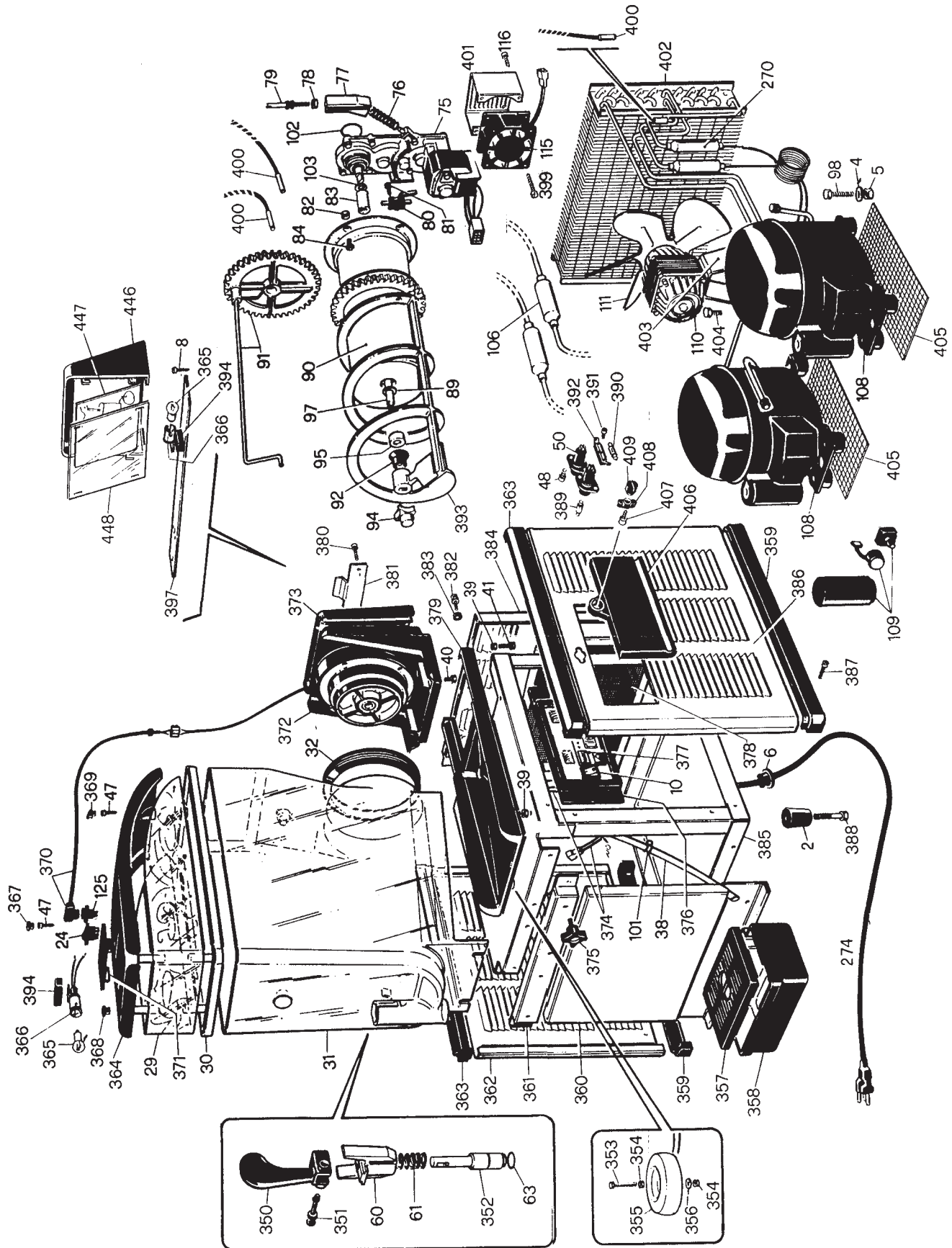

Exploded View MG23-2B (115/60) (serial number 8195 and higher)

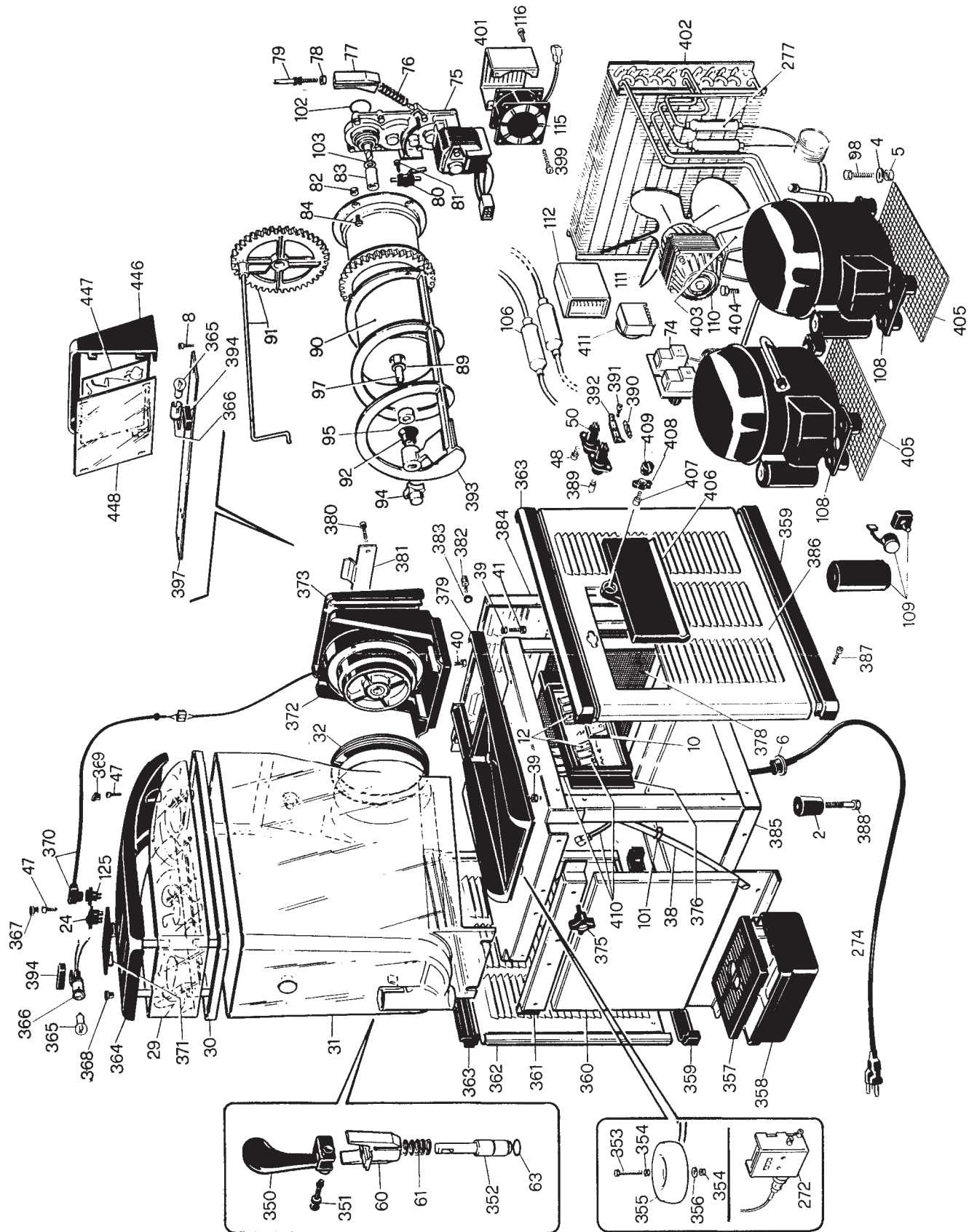

Exploded View G235-2B (220/50)

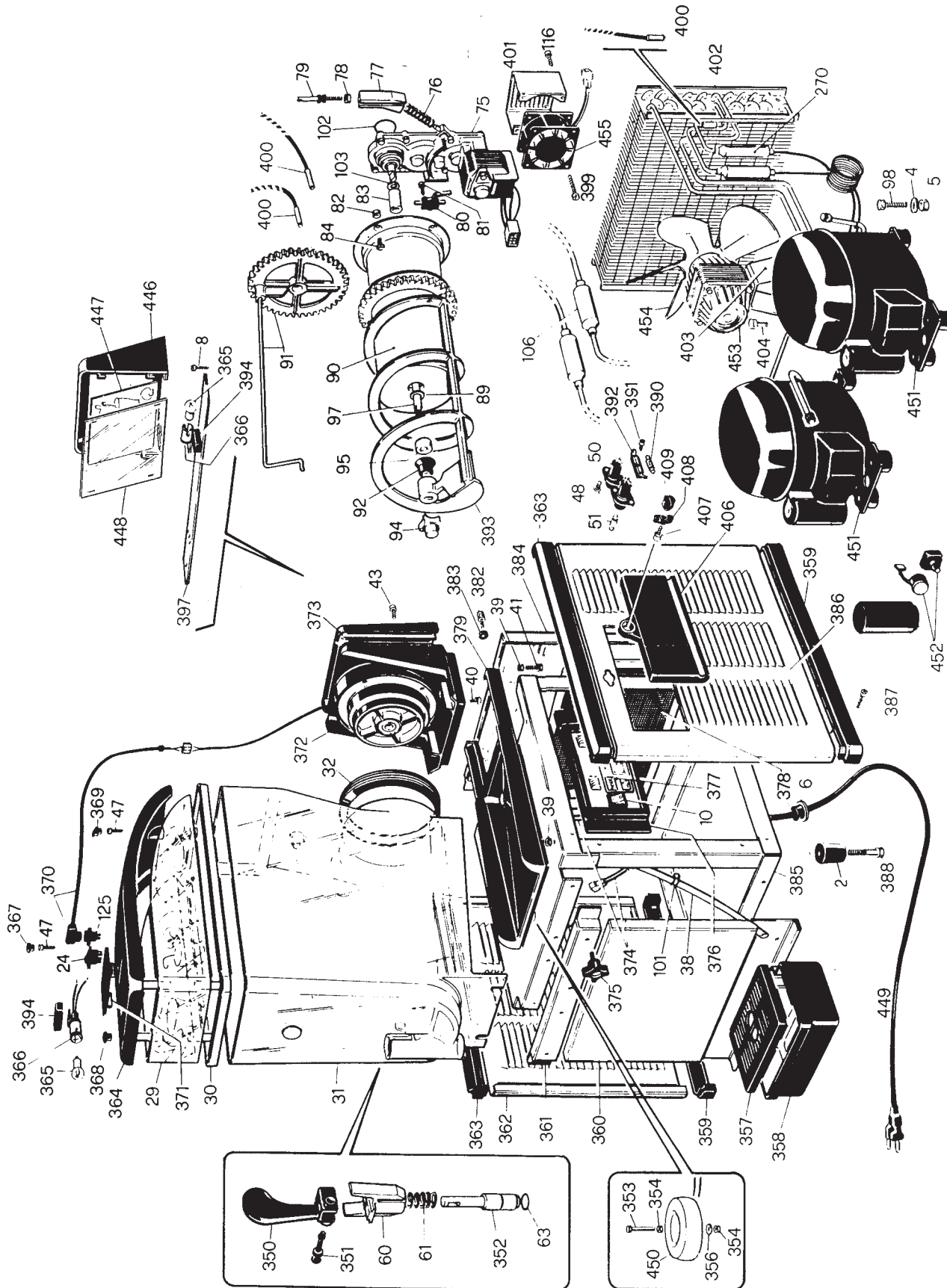

Exploded View G236-2B (220/60)

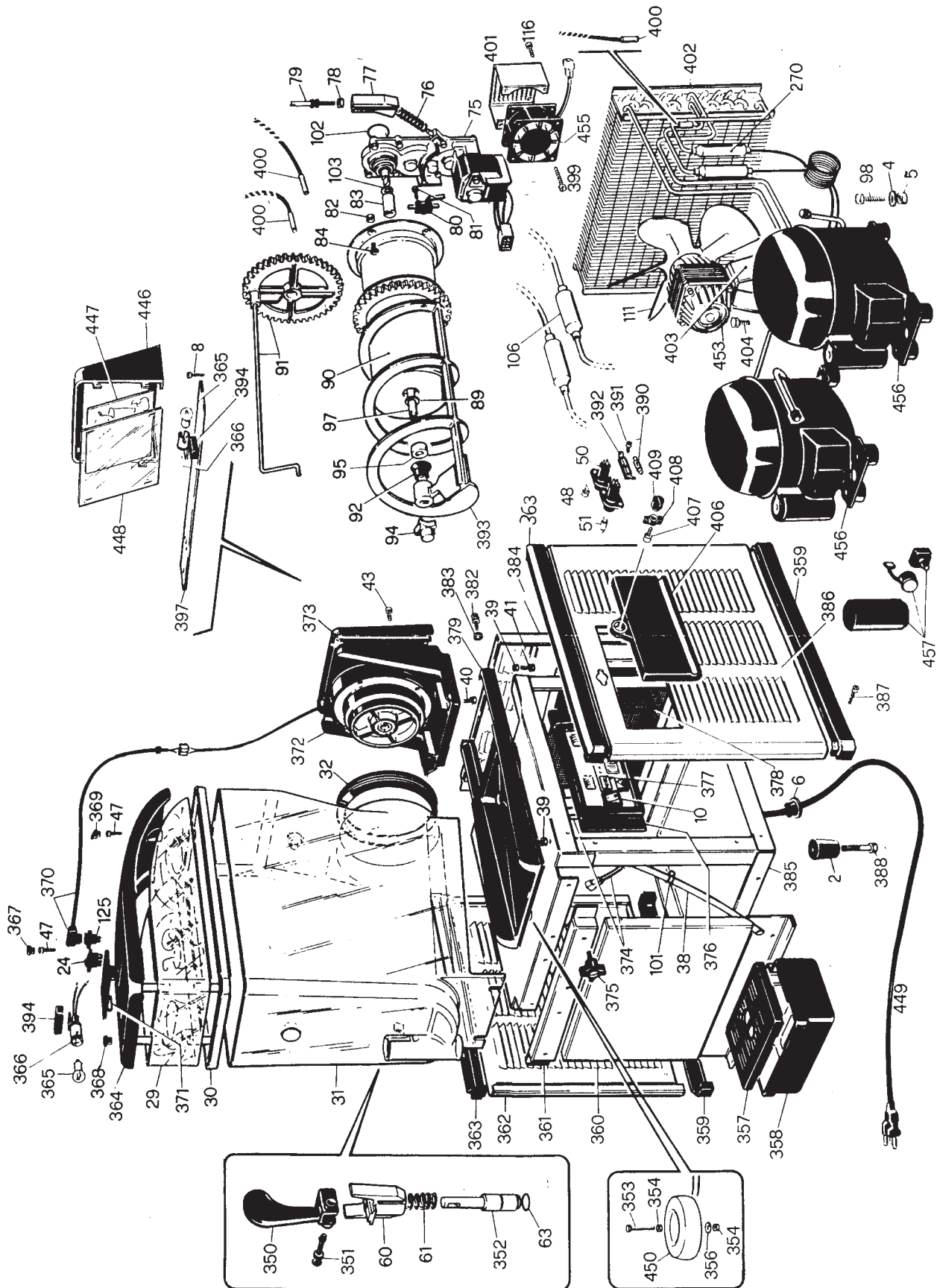

Exploded View MG236-2B (220/60)

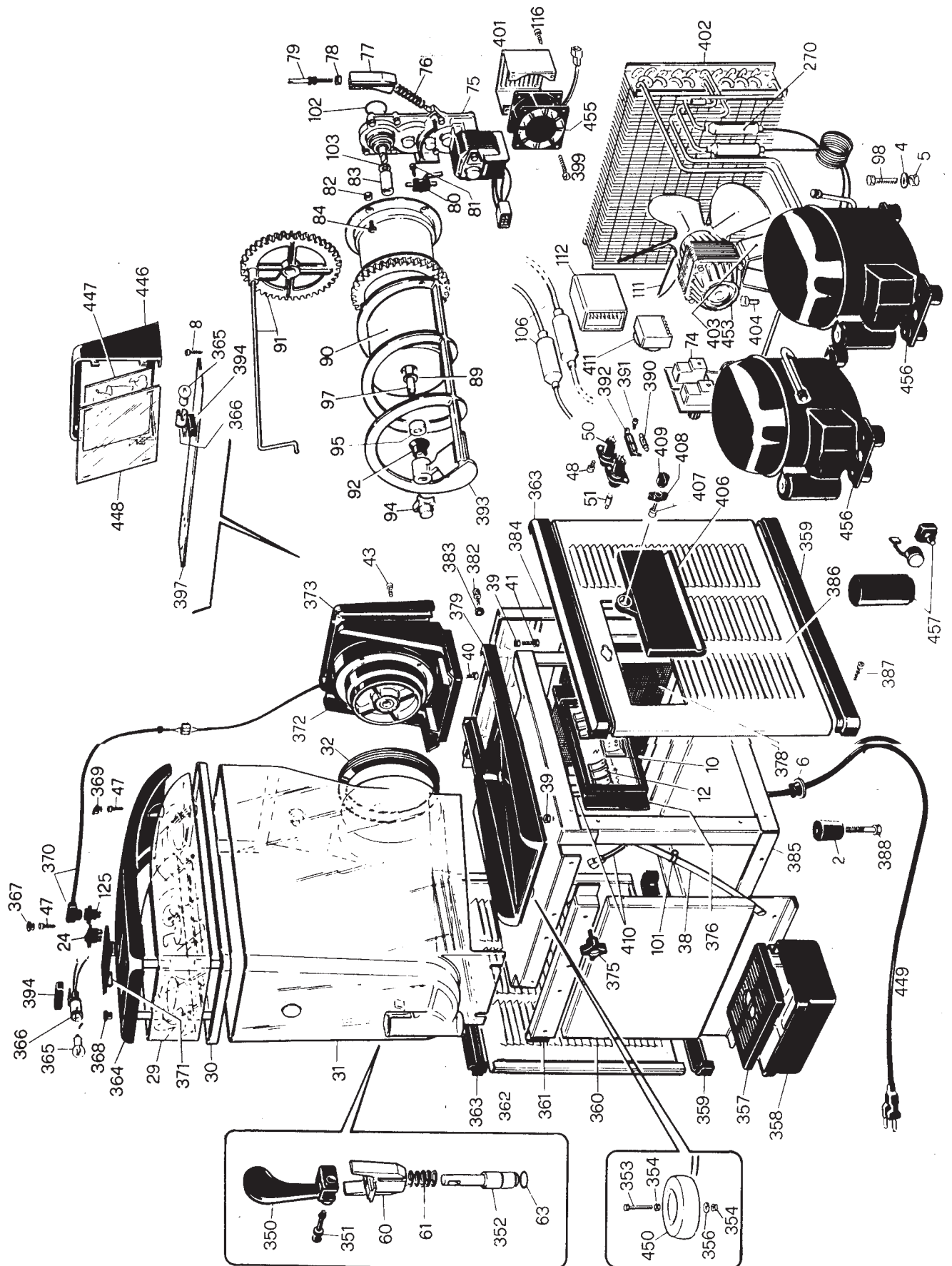

Crathco Granita G & MG Series Parts List

ITEM NO.	PART NO	DESCRIPTION	ITEM NO.	PART NO	DESCRIPTION
2	90000	Supporting Foot	364	90415	Black Merchandiser Cover
4	90002	Washer	365	90142	Incandescent Light Bulb (BP1156CL)
5	90003	Nut	366	90141	Incandescent Light Socket
6	90004	Bushing for Cord	367	90418	Center Screw Lid Plug
8	90006	Screw	368	90419	Front Screw Lid Plug
10	90007	General Switch	369	90420	Rear Screw Lid Plug
12	90008	Function Switch (MG Series)	370	90421	Wiring for Black Lid w/Cord
24	90015	Lid Light Switch	371	90422	Black Cover For Light Bulb
29	90391	Lid Merchandiser, city scene	372	90423	Black Evaporator Support
30	90021	Bottom of Lid	373	90424	Black Cover for Evaporator Support
31	90022	Bowl, standard	374	90425	Wiring,PC Control Board (G Series)
32	90023	Seal for Bowl	375	90426	Black Knob to Secure Bowl
38	90027	Drain Tube	376	90427	Control Board Mounting Plate
39	90028	Nut	377	90428	PC Control Board, Electronic
40	90029	Screw	378	90429	Filter Inlet Air
41	90030	Hex Head Nut Screw	379	90430	Black Top Tray
43	90470	Screw	380	90431	Screw
47	90033	Screw	381	90432	Back-Lit Merchandiser Panel Bracket
48	90034	Screw	382	90433	Knob Rear Panel
50	90036	Fuse Holder	383	90434	O-ring Knob,Rear Panel
51	90471	Fuse, 16 Amp (220V)	384	90435	SS Back Panel
60	90043	Dispensing Valve Upper Body	385	90436	Painted Frame
61	90044	Dispensing Valve Spring	386	90437	Stainless Steel Right Side Panel
63	90046	Dispensing Valve O-ring	387	90438	Screw
74	90048	Thermostat (MG Series)	388	90439	Screw (Foot)
75	90049	Gear Motor	389	90337	Main Fuse 20A
76	90050	Consistency Control Spring	390	90441	5A Fuse
77	90051	Bushing Consistency Control Spring	391	90442	Screw
78	90052	Nut	392	90443	5A Fuse Holder
79	90053	Consistency Control Pin	393	90444	Auger, Granita One Piece
80	90054	Limit Microswitch	394	90445	Bulb Insulator, Rear Merchandiser
81	90055	Screw	395	90446	Screw (Single Pc. Rear Merchandiser)
82	90056	Nut	396	90447	Back-Lit Merchandiser Support (Single Pc.)
83	90057	Bushing Spindle Connection	397	90448	Bulb Bracket, Rear Merchandiser
84	90058	Screw	398	90449	Back-Lit Cover (Single Pc.)
89	90063	Washer for Front Bushing	399	90450	Screw
90	90064	Evaporator	400	90451	Thermister (G Series)
91	90065	Upper Mixing Unit	401	90452	Fan Motor Cover
92	90066	Shaft Seal, Rubber Bell Shaped	402	90453	Condenser
94	90068	Securing Nut for Auger	403	90454	Condenser Fan Motor Bracket
95	90069	Spindle Bushing	404	90455	Screw
97	90071	Drive Shaft	405	90456	Compressor Mouting Plate
98	90072	Screw	406	90457	Control Box Cover Black
101	90075	Hose Clamp	407	90458	Screw
102	90076	O-ring	408	90459	Control Board Cover Lock
103	90077	Washer for Rear Bushing	409	90460	Control Board Cover Key
106	90078	Accumalator	410	90395	Complete Wiring (MG Series)
108	90080	Compressor (115/60)	411	90132	Timer, Defrost (MG Series)
109	90081	Compressor Electrical Parts (115/60)	446	90472	Back-lit Merchandiser, Panel Bracket (Dual Pc.)
110	90082	Condenser Fan Motor (115/60)	306	90392	Rear Merchandiser, City Scene (Single Pc.)
111	90083	Impeller (60Hz)	447	90397	Rear Merchandiser Graphic, City Scene (Dual Pc.)
112	90084	Control Box Timer (MG Series)	448	90473	Transparent Surface (Dual Pc Rear Merchandiser)
115	90085	Gear Motor Fan (115/60)	449	90474	Cord with Plug (220V)
116	90086	Screw	450	90475	Transformer (IN 230 OUT 12)
125	90102	Lid Socket	451	90476	Compressor (220/50)
270	90464	Filter Drier	452	90477	Compressor Electrical Parts (220/50)
272	90129	High Pressure Cutout Switch	453	90478	Condensor Fan Motor (220V)
274	90005	Cord with Plug AWG14(20A)	454	90479	Impeller (220/50)
277	90465	Filter drier, dual connection	455	90480	Gear Motor Fan (220V)
350	90401	Dispensing Valve Handle, Black	456	90481	Compressor (220/60)
351	90402	Handle Securing Pin, Black	457	90482	Compressor Electrical Parts (220/60)
352	90403	Dispensing Valve, Lower Body	90104		Seal Replacement Kit
353	90404	Screw	90106		Brush 1/4" Ceaning
354	90405	Nut,M5 DIN 934	90107		Brush, Valve 1" Ceaning
355	90406	Transformer(IN 115V out 12) G&MG	90110		Shaft Replacement Kit
356	90407	Washer 5X15X1.5	90112		Food Grade Lubricant
357	90408	Drip Tray Grid Black	90177		Bowl, 2-gallon
358	90409	Black Drip Tray	90178		Complete bowl cover G & MG Series
359	90410	Black Lower Trim	90381		Instruction Manual, G & MG Series
360	90411	Stainless Steel Lower Front Panel	90386		Care & Cleaning Inst., Lam. Card
361	90412	Stainless Steel Upper Front Panel	90468		Control Box Cover Assy. Blk
362	90413	Stainless Steel Left Side Panel	90469		Complete Dispensing Valve Black
363	90414	Black Upper Trim	90483		9 ltr. Max Bowl Label

GEAR MOTOR EXPLODED VIEW

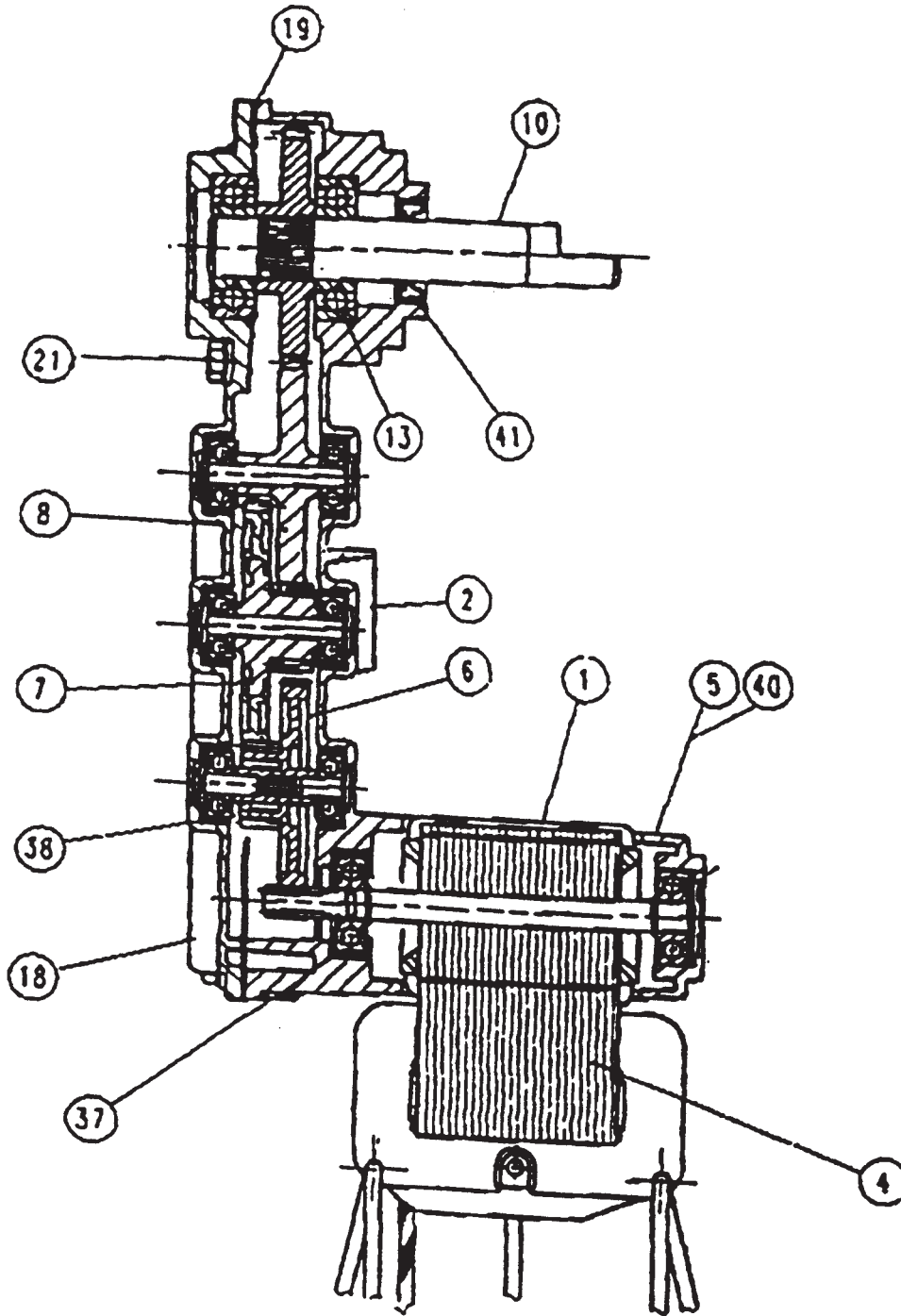

Item #	Description	Part No.
1	ROTOR WITH TWO BEARINGS	90174
4	ARMATURE	90169
6	DRIVE GEAR WITH BEARING	90165
7	IDLER GEAR WITH BEARING	90166
10	OUTPUT SHAFT AND GEAR	90171
13	OUTPUT SHAFT BEARING	90170
19	HOUSING GASKET	90167
41	OUTPUT SHAFT SEAL	90168

REFRIGERATION DIAGRAM MODEL G SERIES (115V/220V)

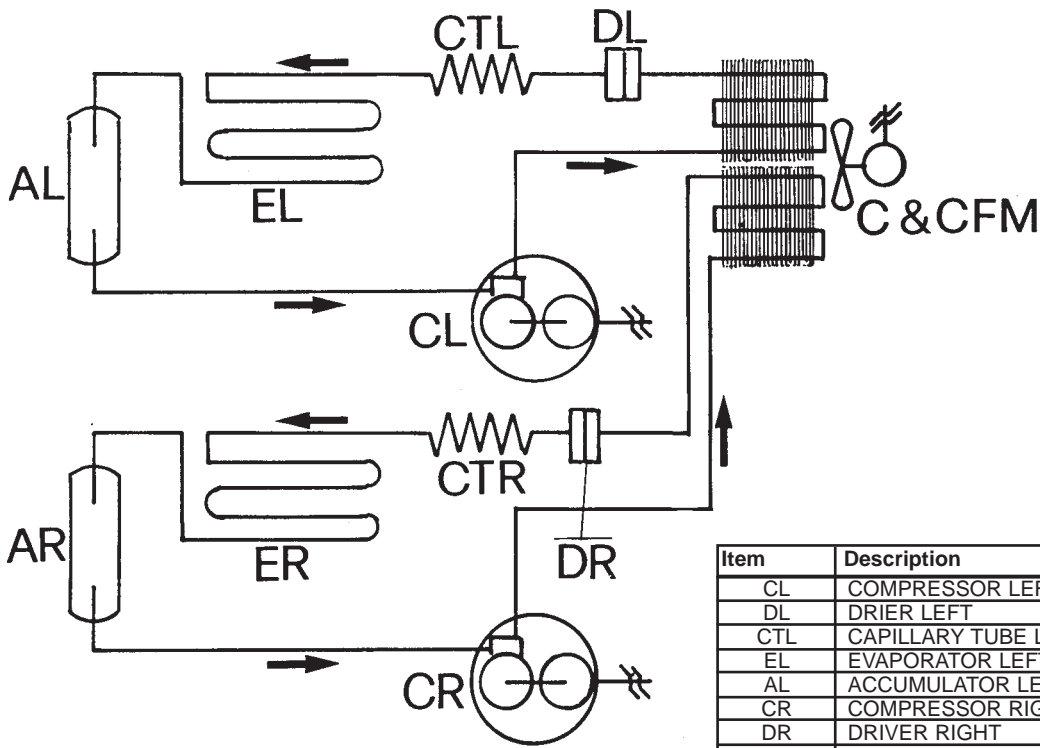

Item	Description
CL	COMPRESSOR LEFT
DL	DRIER LEFT
CTL	CAPILLARY TUBE LEFT
EL	EVAPORATOR LEFT
AL	ACCUMULATOR LEFT
CR	COMPRESSOR RIGHT
DR	DRIVER RIGHT
CRT	CAPILLARY TUBE RIGHT
ER	EVAPORATOR RIGHT
AR	ACCUMULATOR RIGHT
C & CFM	CONDENSER AND CONDENSER FAN MOTOR

REFRIGERATION DIAGRAM MODEL MG SERIES (115V)

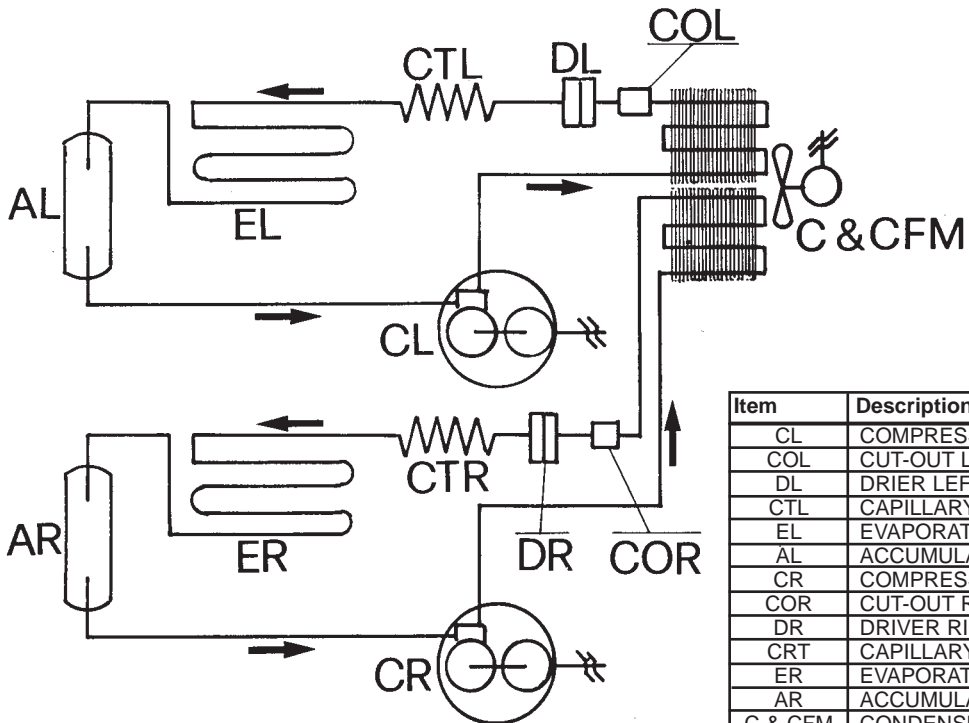

Item	Description
CL	COMPRESSOR LEFT
COL	CUT-OUT LEFT
DL	DRIER LEFT
CTL	CAPILLARY TUBE LEFT
EL	EVAPORATOR LEFT
AL	ACCUMULATOR LEFT
CR	COMPRESSOR RIGHT
COR	CUT-OUT RIGHT
DR	DRIVER RIGHT
CRT	CAPILLARY TUBE RIGHT
ER	EVAPORATOR RIGHT
AR	ACCUMULATOR RIGHT
C & CFM	CONDENSER AND CONDENSER FAN MOTOR

REFRIGERATION DIAGRAM MODEL MG SERIES (220V)

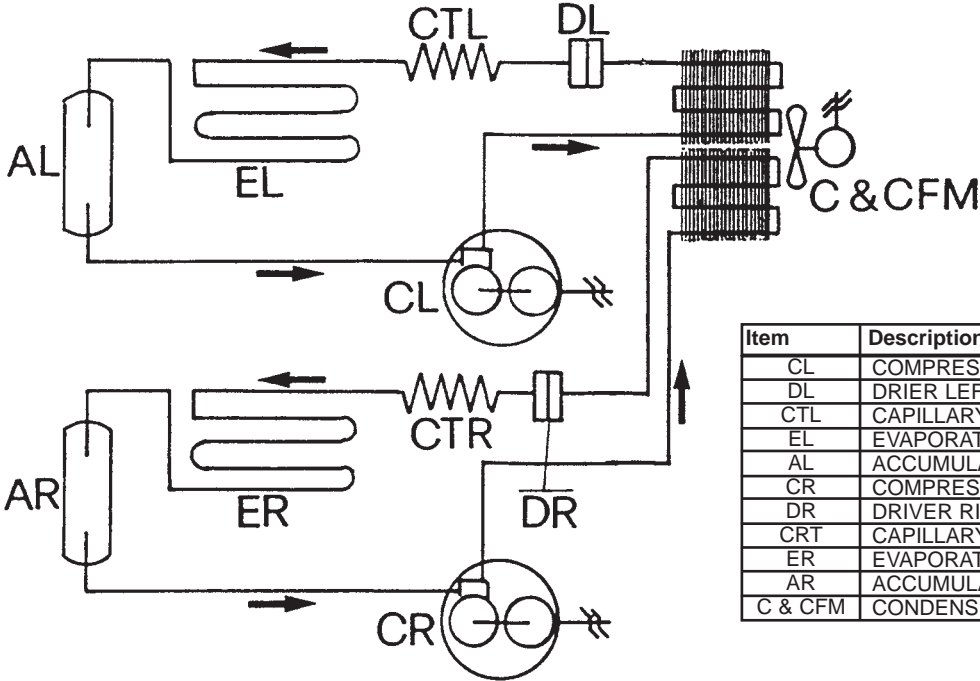

Item	Description
CL	COMPRESSOR LEFT
DL	DRIER LEFT
CTL	CAPILLARY TUBE LEFT
EL	EVAPORATOR LEFT
AL	ACCUMULATOR LEFT
CR	COMPRESSOR RIGHT
DR	DRIER RIGHT
CTR	CAPILLARY TUBE RIGHT
ER	EVAPORATOR RIGHT
AR	ACCUMULATOR RIGHT
C & CFM	CONDENSER AND CONDENSER FAN MOTOR

ELECTRICAL DIAGRAM MODEL - MG SERIES (115)

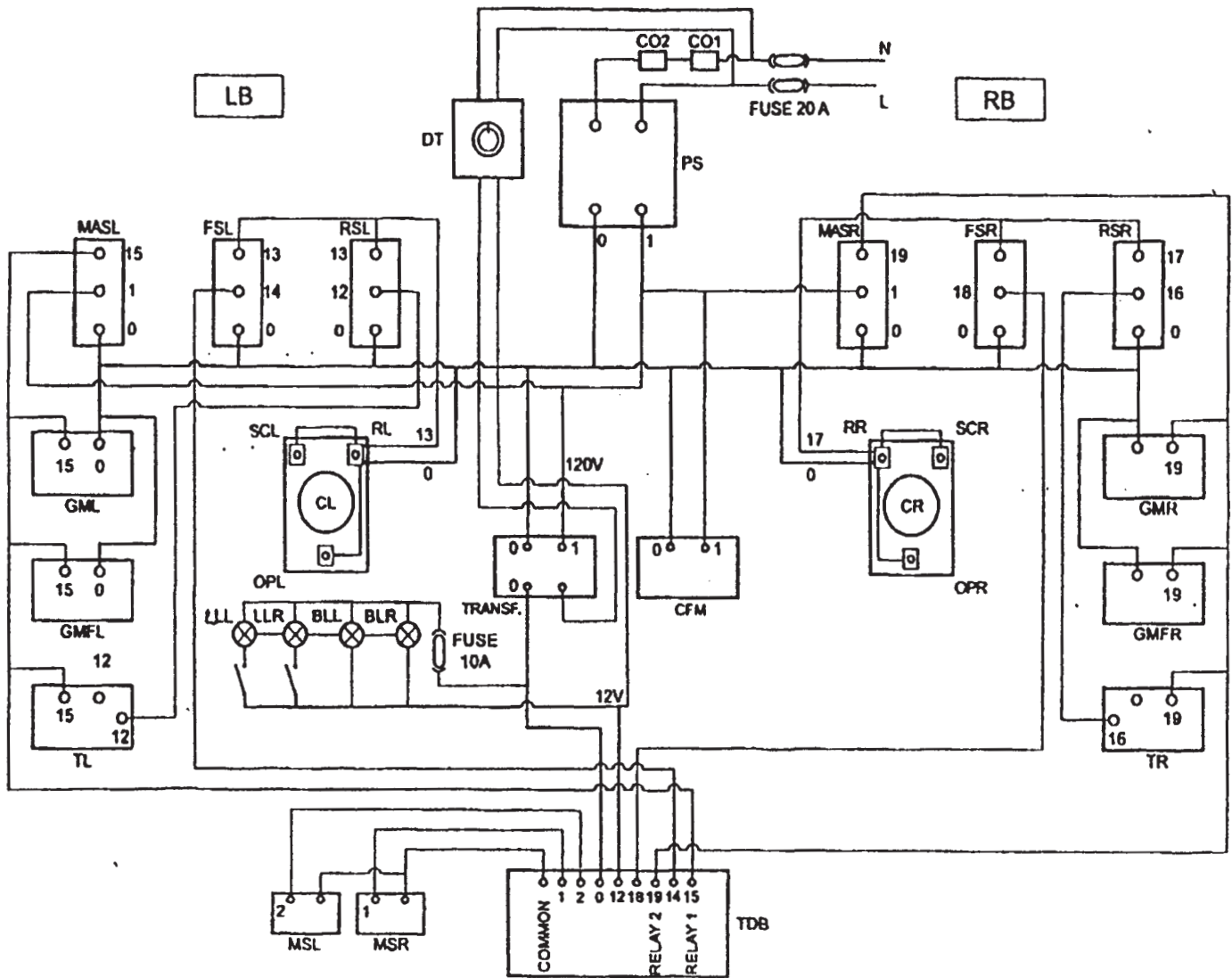

Item	Description	Item	Description
LB	LEFT BOWL	TR	THERMOSTAT RIGHT
RB	RIGHT BOWL	CL	COMPRESSOR LEFT
CO1	H.P. CUT-OUT SWITCH 1	RL	COMPRESSOR RELAY LEFT
CO2	H.P. CUT-OUT SWITCH 2	SCL	STARTING CAPACITOR LEFT
PS	POWER SWITCH	OPL	OVERLOAD PROTECTOR LEFT
DT	DEFROST TIMER	CR	COMPRESSOR RIGHT
MASL	MIXING AUGER SWITCH LEFT	RR	COMPRESSOR RELAY RIGHT
FSL	FREEZING SWITCH LEFT	SCR	STARTING CAPACITOR RIGHT
RSL	REFRIGERATING SWITCH LEFT	OPR	OVERLOAD PROTECTOR RIGHT
MASR	MIXING AUGER SWITCH RIGHT	TRANSF	TRANSFORMER
FSR	FREEZING SWITCH RIGHT	CFM	CONDENSER FAN MOTOR
RSR	REFRIGERATING SWITCH RIGHT	LLL	LID LAMP LEFT
GML	GEAR MOTOR LEFT	LLR	LID LAMP RIGHT
GMFL	GEAR MOTOR FAN LEFT	MSL	MICROSWITCH LEFT
TL	THERMOSTAT LEFT	MSR	MICROSWITCH RIGHT
GMR	GEAR MOTOR RIGHT	TDB	TIME DELAY BOARD
GMFR	GEAR MOTOR FAN RIGHT	BLL	BACK LAMP LEFT
		BLR	BACK LAMP RIGHT

ELECTRICAL DIAGRAM MODEL - MG SERIES (220V)

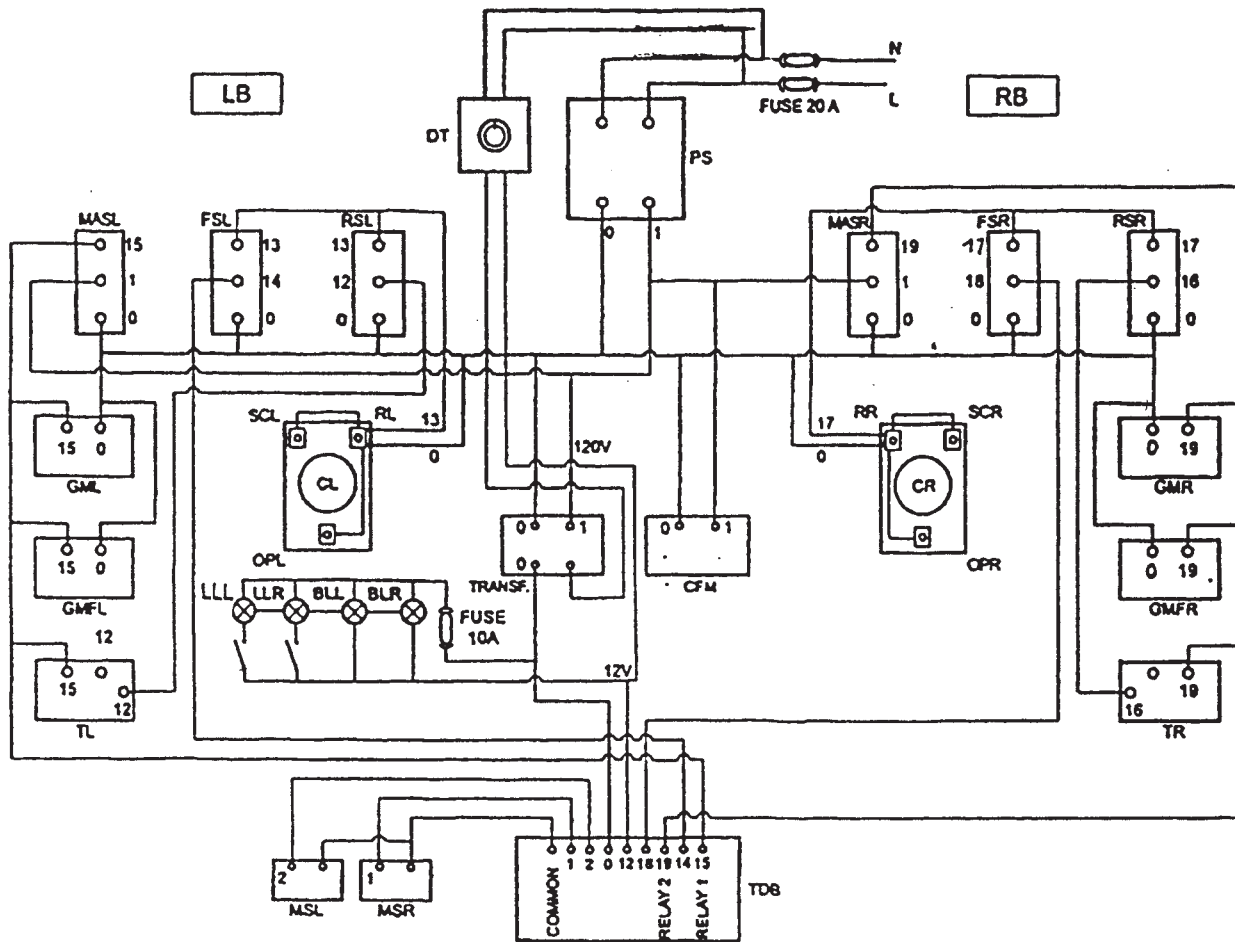

Item	Description	Item	Description
LB	LEFT BOWL	RL	COMPRESSOR RELAY LEFT
RB	RIGHT BOWL	SCL	STARTING CAPACITOR LEFT
PS	POWER SWITCH	OPL	OVERLOAD PROTECTOR LEFT
DT	DEFROST TIMER	CR	COMPRESSOR RIGHT
MASL	MIXING AUGER SWITCH LEFT	RR	COMPRESSOR RELAY RIGHT
FSL	FREEZING SWITCH LEFT	SCR	STARTING CAPACITOR RIGHT
RSL	REFRIGERATING SWITCH LEFT	OPR	OVERLOAD PROTECTOR RIGHT
MASR	MIXING AUGER SWITCH RIGHT	TRANSF.	TRANSFORMER
FSR	FREEZING SWITCH RIGHT	CFM	CONDENSER FAN MOTOR
RSR	REFRIGERATING SWITCH RIGHT	LLL	LID LAMP LEFT
GML	GEAR MOTOR LEFT	LLR	LID LAMP RIGHT
GMFL	GEAR MOTOR FAN LEFT	MSL	MICROSWITCH LEFT
TL	THERMOSTAT LEFT	MSR	MICROSWITCH RIGHT
GMR	GEAR MOTOR RIGHT	TDB	TIME DELAY BOARD
GMFR	GEAR MOTOR FAN RIGHT	BLL	BACK LAMP LEFT
TR	THERMOSTAT RIGHT	BLR	BACK LAMP RIGHT
CL	COMPRESSOR LEFT		

ELECTRICAL DIAGRAM MODEL - G SERIES (115V/220V)

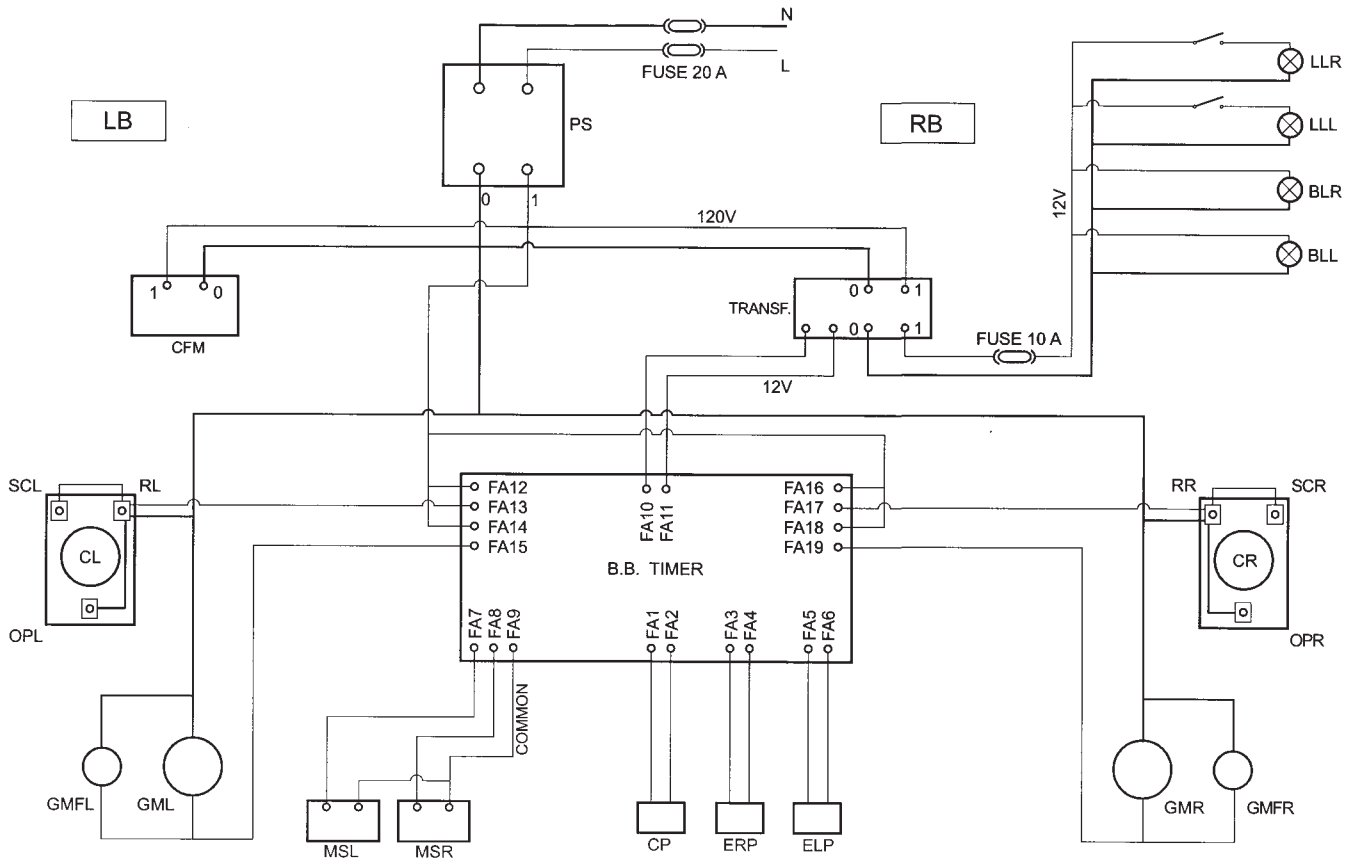

Item	Description	Item	Description
LB	LEFT BOWL	OPL	OVERLOAD PROTECTOR LEFT
RB	RIGHT BOWL	CR	COMPRESSOR RIGHT
PS	POWER SWITCH	OPR	OVERLOAD PROTECTOR RIGHT
CFM	CONDENSER FAN MOTOR	GML	GEAR MOTOR LEFT
TRANSF.	TRANSFORMER (IN 120V OUT 12V)	GFML	GEAR MOTOR FAN LEFT
BLL	BACK LAMP LEFT	GMR	GEAR MOTOR RIGHT
BLR	BACK LAMP RIGHT	GMFR	GEAR MOTOR FAN RIGHT
LLL	LID LAMP LEFT	MSL	MICROSWITCH LEFT
LLR	LID LAMP RIGHT	MSR	MICROSWITCH RIGHT
B.B. TIMER	CONTROLLER BOARD	CP	CONDENSER PROBE
CL	COMPRESSOR LEFT	ERP	EVAPORATOR RIGHT PROBE
RL	COMPRESSOR RELAY LEFT	ELP	EVAPORATOR LEFT PROBE
SCL	STARTING CAPACITOR LEFT		



WWW.MargaritaMachineParts.Net



GRINDMASTER[®]
CORPORATION

Grindmaster[®] Coffee Grinders and Brewers • Espresso[®] Espresso Machines • Crathco[®] Hot Beverage Dispensers
Crathco[®] Cold and Frozen Beverage Dispensers • American Metal Ware[®] Coffee and Tea Systems

www.frozendrinkmadness.com , Randy@frozendrinkmadness.com

972-276-2757, Fax 972-423-9993