

BUNN®

AFPO-2
AFPO-2 SL
AFPO-3
AFPO-3 SL

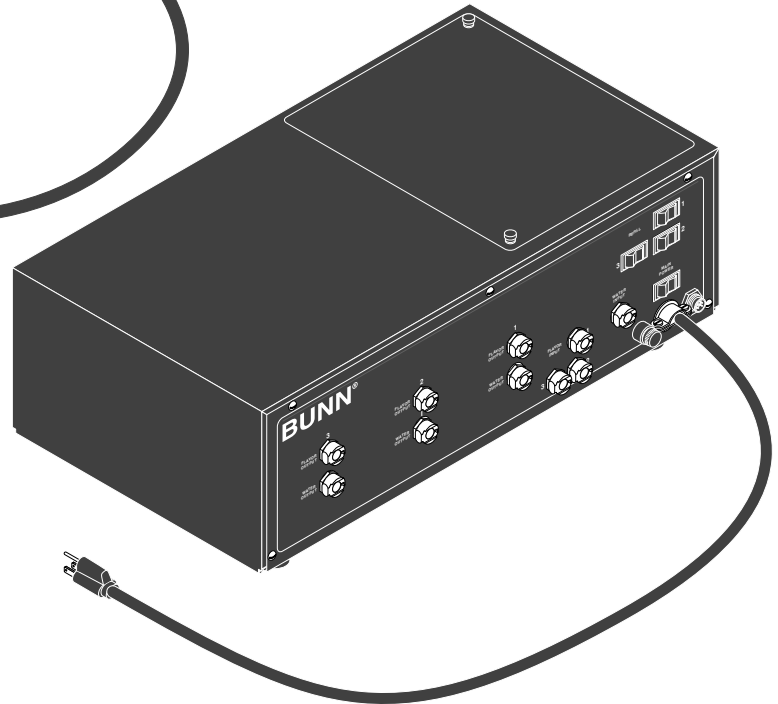
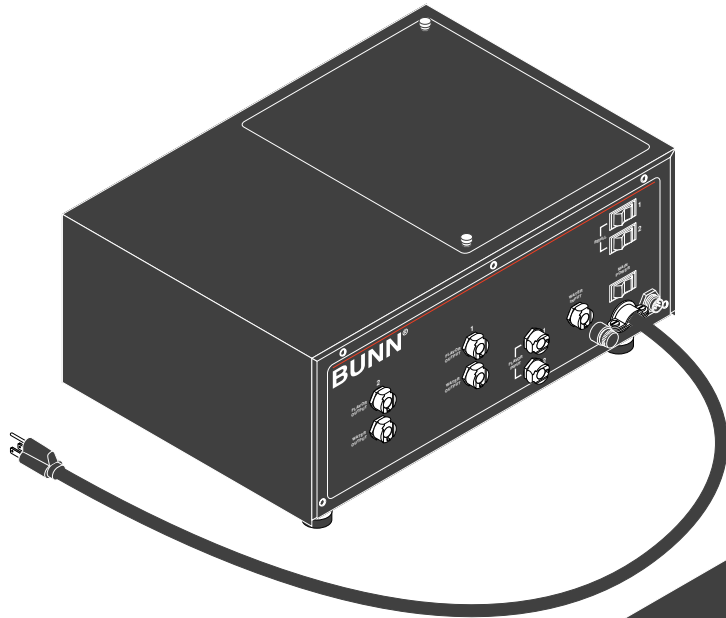

OPERATING & SERVICE MANUAL

BUNN-O-MATIC CORPORATION

POST OFFICE BOX 3227

SPRINGFIELD, ILLINOIS 62708-3227

PHONE: (217) 529-6601 FAX: (217) 529-6644

INTRODUCTION

This equipment supplies a liquid concentrate mixed with water at various ratios to the hoppers on the CDS-2 or CDS-3 dispensers. It is for indoor use only on a sturdy counter or shelf.

WARRANTY

Bunn-O-Matic Corp. ("Bunn") warrants the equipment manufactured by it to be commercially free from defects in material and workmanship existing at the time of manufacture and appearing within one year from the date of installation. In addition:

1.) Bunn warrants electronic circuit and/or control boards to be commercially free from defects in material and workmanship for two years from the date of installation.

2.) Bunn warrants the compressor on refrigeration equipment to be commercially free from defects in material and workmanship for two years from the date of installation.

3.) Bunn warrants that the grinding burrs on coffee grinding equipment will grind coffee to meet original factory screen sieve analysis for three years from date of installation or for 30,000 pounds of coffee, whichever comes first.

This warranty does not apply to any equipment, component or part that was not manufactured by Bunn or that, in Bunn's judgement, has been affected by misuse, neglect, alteration, improper installation or operation, improper maintenance or repair, damage or casualty.

THE FOREGOING WARRANTY IS EXCLUSIVE AND IS IN LIEU OF ANY OTHER WARRANTY, WRITTEN OR ORAL, EXPRESS OR IMPLIED, INCLUDING, BUT NOT LIMITED TO, ANY IMPLIED WARRANTY OF EITHER MERCHANTABILITY OR FITNESS FOR A PARTICULAR PURPOSE. The agents, dealers or employees of Bunn are not authorized to make modifications to this warranty or to make additional warranties that are binding on Bunn. Accordingly, statements by such individuals, whether oral or written, do not constitute warranties and should not be relied upon.

The Buyer shall give Bunn prompt notice of any claim to be made under this warranty by telephone at (217) 529-6601 or by writing to Post Office Box 3227, Springfield, Illinois, 62708-3227. If requested by Bunn, the Buyer shall ship the defective equipment prepaid to an authorized Bunn service location. If Bunn determines, in its sole discretion, that the equipment does not conform to the warranty, Bunn shall repair the equipment with no charge for parts during the warranty period and no charge for labor by a Bunn Authorized Service Representative during the warranty period. If Bunn determines that repair is not feasible, Bunn shall, at its sole option, replace the equipment or refund the purchase price for the equipment.

THE BUYER'S REMEDY AGAINST BUNN FOR THE BREACH OF ANY OBLIGATION ARISING OUT OF THE SALE OF THIS EQUIPMENT, WHETHER DERIVED FROM WARRANTY OR OTHERWISE, SHALL BE LIMITED, AS SPECIFIED HEREIN, TO REPAIR OR, AT BUNN'S SOLE OPTION, REPLACEMENT OR REFUND.

In no event shall Bunn be liable for any other damage or loss, including, but not limited to, lost profits, lost sales, loss of use of equipment, claims of Buyer's customers, cost of capital, cost of down time, cost of substitute equipment, facilities or services, or any other special, incidental or consequential damages.

USER NOTICES

Carefully read and follow all notices on the equipment and in this manual. They were written for your protection. All notices are to be kept in good condition. Replace any unreadable or damaged labels.

This equipment is to be installed to comply with the Basic Plumbing Code of the Building Officials and Code Administrators International, Inc. (BOCA) and the Food Service Sanitation Manual of the Food and Drug Administration (FDA).

00656.0000

WARNING

- DO NOT OVERLOAD CIRCUIT.
- ALWAYS ELECTRICALLY GROUND THE CHASSIS OR ADAPTOR PLUG.
- DO NOT DEFORM PLUG OR CORD.
- FOLLOW NATIONAL AND LOCAL ELECTRICAL CODES.
- KEEP COMBUSTIBLES AWAY.

FAILURE TO COMPLY RISKS EQUIPMENT DAMAGE, FIRE, OR SHOCK HAZARD.

READ THE ENTIRE OPERATING MANUAL BEFORE USING THIS PRODUCT

00986.0002E 5/98 © 1994 Bunn-O-Matic Corporation

00986.0002

ELECTRICAL REQUIREMENTS

CAUTION - The dispenser must be disconnected from the power source until specified in *Initial Set-Up*.

The 120 volt version of this dispenser has an attached cordset and requires 2-wire, grounded service rated 120 volts ac, 15 amp, single phase, 60 Hz. The mating connector must be a NEMA 5-15R.

The 230 volt CE version requires 2 wire, grounded service rated 230V ac, single phase, 50 Hz.

The 200 volt or 240 volt versions require 2 wire, grounded service rated 200 volts ac or 240 volts ac, single phase, 50 Hz.

(Refer to the dispenser's data plate for exact voltage requirement.)

Electrical Hook-Up

CAUTION – Improper electrical installation will damage electronic components.

1. An electrician must provide electrical service as specified.
2. Using a voltmeter, check the voltage and color coding of each conductor at the electrical source.
3. Connect the dispenser to the power source.

PLUMBING REQUIREMENTS

This dispenser must be connected to a **cold water** system with operating pressure between 20 and 90 (138 and 620 kPa) psi from a ½" or larger supply line. A shut-off valve should be installed in the line before the dispenser. Install a regulator in the line when pressure is greater than 90 psi (620 kPa) to reduce it to 50 psi (345 kPa). The water inlet fitting is ¼" flare.

NOTE - Bunn-O-Matic recommends ¼" copper tubing for installations of less than 25 feet and ⅜" for more than 25 feet from the ½" water supply line. At least 18 inches of an FDA approved flexible beverage tubing, such as reinforced braided polyethylene or silicone, before the brewer will facilitate movement to clean the countertop. Tubing is supplied by Bunn-O-Matic (part number 00326-0000). Bunn-O-Matic does not recommend the use of a saddle valve to install the brewer. The size and shape of the hole made in the supply line by this type of device may restrict water flow

This equipment must be installed to comply with the Basic Plumbing Code of the Building Officials and Code Administrators International, Inc. (BOCA) and the Food Service Sanitation Manual of the Food and Drug Administration (FDA).

INITIAL SET-UP

NOTE: This refill unit should not be used to initially fill the hopper. Running the motor for extended periods will trip the thermal switch. The thermal switch will reset, but requires up to 30 minutes of cooling time.

NOTE: Hoses and product container connectors are not supplied. Fitting, clamps and labels are supplied. Make hose assemblies as required. Refer to *PIPING DIAGRAM* on page 22.

1. Assemble hoppers with probe housing assemblies to CDS-2, CDS-3 or modify existing hoppers using template provided.
2. Make sure probe housing assembly is pushed down into slots on back of hoppers.
3. Install cable assembly to the lower right front of the auto refill box and the probe housing assemblies on the hoppers. The connectors on the cable pushes in and cap rotates 1/4 turn to lock into position.
4. Run output tubes from auto refill box to the quick disconnects in the hoppers.

NOTE: Make sure numbers on the labels match up. Cable#1 with Hose#1, Cable#2 with Hose#2,....etc.

INITIAL SET-UP (cont.)

5. Connect one end of input hoses to the auto refill box and the other end to the product container. Product container connectors (BIB) are not supplied. Install your own interface.
6. Connect water line to auto refill box. A minimum of 20 psi (138 kPa) is required.
NOTE: Make sure all connections are made before connecting the auto refill box to the power source.
7. Each product container has an ON/OFF refill switch located on the front of the auto refill box. A second switch for each hopper is at the probe housing assembly. These are 3 position switches, high level, low level and a center "OFF" position.
8. Place the main ON/OFF switch and ON/OFF refill switches in the "OFF" position.
9. Make sure all hoses are connected. Place the main ON/OFF switch in the "ON" position.
10. Place one of the ON/OFF refill switches in the "ON" position, after a four second delay product will begin to flow through the hoses into the hopper. Be sure the switch selected is filling the correct hopper, if not, check the labels. See **NOTE** in step #4.
11. To test refill circuit short out probes on one of the hoppers with a screwdriver, so that hopper should shut off. Remove the screwdriver and the hopper will start to fill again after a four second delay. If hopper does not start to fill, check labels, refer to **NOTE** in step #4.
12. To change mix ratio refer to *MIX RATIO ADJUSTMENTS*.

CLEANING

RECOMMENDED WEEKLY CLEANING:

This should be done in conjunction with the recommended weekly cleaning of your CDS-2 or CDS-3 machine. The CDS Hoppers must be empty before starting.

1. Prepare a 1 gallon cleaning solution consisting of 1 gallon of hot water and a sanitizing cleaner which contains 3-5% chlorine based sanitizer. Mix per manufacturers instructions
2. Remove connectors from each concentrate container and place them directly into the cleaning solution.
3. Energize each refill station and allow the cleaning solution to pump through the system into the hoppers. The cleaning procedure should remove the color stains from the tubing. If not, prepare another gallon of cleaning solution and repeat.
4. After the cleaning solution has been pumped into the hoppers, rinse the cleaning solution container with hot water.
5. Fill the cleaning solution container with hot water. Energize each refill station and rinse thoroughly. The amount of clean hot rinse water should equal the amount of cleaning solution pumped through the system.
6. Empty the hoppers of your CDS machine and follow the recommended cleaning instructions.
NOTE: The hoses should be checked monthly for deterioration, cracks and possible discoloration from some concentrates. Replace the tubing when necessary.

MIX RATIO ADJUSTMENTS

1. Remove the top access panel.
2. Connect the test hose to the "WATER OUTPUT" to be adjusted.
3. Connect the provided hose (or other suitable water hose) to the "WATER INPUT".
4. Ensure water regulator is set at 20 psi(137.9 kPa). Press the "TEST OUTPUT" switch and while water is flowing from the test hose, check that the gauge reads 20.
5. Place a one-cup container under the test hose. Press the "TEST OUTPUT" switch, and carefully measure and note the elapsed time from when water first flows from the test hose to when one cup of water has been dispensed. Hoses and tubing should be primed and free of substantial air spaces and/or bubbles prior to calibration.

MIX RATIO ADJUSTMENTS(cont.)

6. Compare results with chart or formula below.
7. If the time observed is too short or long, turn the needle valve clockwise or counterclockwise, respectively, a little at a time. Repeat from the preceding step until correct.

Mix ratio (water/flavor)	Time for FLAVOR OUTPUT (1/2 cup)	Time for WATER OUTPUT (1 cup)
1+1	assume 20 sec. or obtain time per note below	40 sec. or 2 times flavor output time
2+1	assume 20 sec. or obtain time per note below	20 sec. or equal to flavor output time
3+1	assume 20 sec. or obtain time per note below	13.3 sec. or 0.67 times flavor output time
4+1(see below)	assume 20 sec. or obtain time per note below	10 sec. or 0.5 times flavor output time
5+1	assume 20 sec. or obtain time per note below	8 sec. or 0.4 times flavor output time
6+1	assume 20 sec. or obtain time per note below	6.7 sec. or 0.33 times flavor output time

NOTE: For a typical adjustment, the time for flavor output in the center column above is assumed to be 20 seconds. A more specific flavor pump output time may be obtained prior to adjustment of the needle valve. To do so, connect the flavor to be tested to the “FLAVOR INPUT”, and the test hose to the corresponding “FLAVOR OUTPUT” (make no connection to the “WATER INPUT”). With a one-cup container under the test hose press the corresponding “TEST OUTPUT” switch, and carefully measure and note the elapsed time from when the product first flows from the test hose to when one-half cup of the product has been dispensed. This value may then be used in the formula below. Following flavor pump output measurement, disconnect the flavor line from the “FLAVOR INPUT” and purge remaining product from the line.

Formula for setting mix ratio: To obtain the time for dispensing 1 cup of water, divide the time it takes to dispense one-half cup of product by the first number in the mix ratio and then multiply the result by two.

Example: $W=2(F/X)$ Where W is the time it should take to dispense one cup of water, it took F seconds (20 here) to dispense 1/2 cup of flavor concentrate, we desire a mix ratio X of 4+1 (X will be the first number in the mix ratio, 4).

Therefore: $W = 2/(20/4)$
 $W = 2/5$
 $W = 10 \text{ seconds}$

So if it took 20 seconds to dispense one-half cup of flavor concentrate, and a mix ratio of 4 to 1 is required, the needle valve should be adjusted to dispense 1 cup of water in 10 seconds.

NOTE: Hoses and tubing should be primed and free of substantial air spaces and/or bubbles prior to calibration.

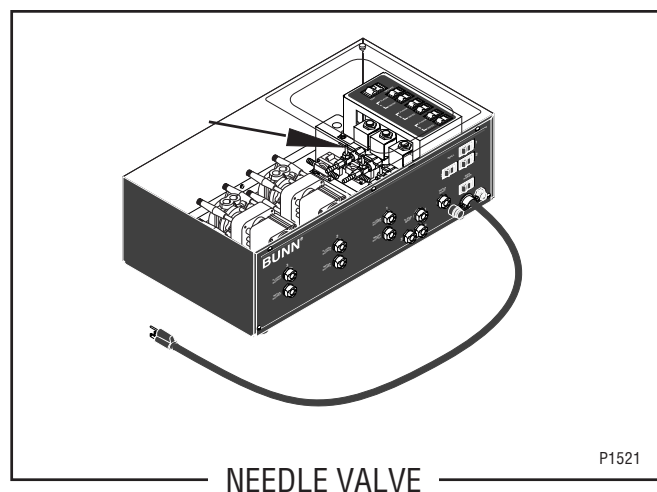

OPERATING CONTROLS

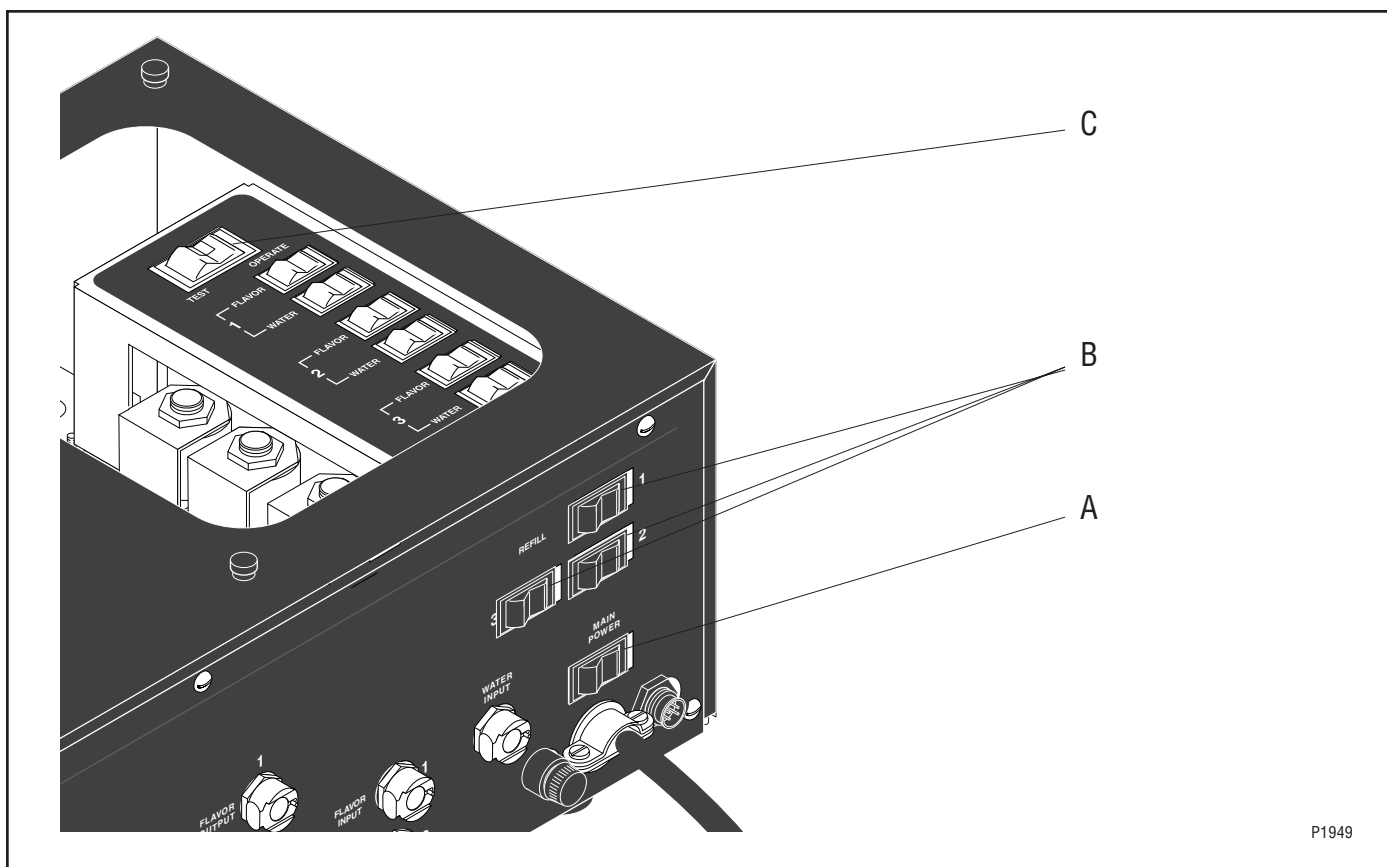

P1949

A. MAIN POWER ON/OFF

The main power ON/OFF switch is located on the right of the front panel just above the power cord.

B. REFILL CIRCUIT ON/OFF

The refill circuit ON/OFF switches are located on the right of the front panel just above the main power switch. These allow each circuit to operate independently.

C. TEST/OPERATE

The TEST/OPERATE switch is located inside the auto-fill box just below the top access cover. For setting flow rates and mix ratios for flavors, place the TEST/OPERATE switch in the "TEST" position. This allows the operator to run the water and flavor lines for each circuit depending on the requirements for the flavor recipe.

D. PROBE CONTROL BOX LOW/OFF/HIGH

On models equipped with a dual level probe, there is a LOW/OFF/HIGH switch located at the probe control box on the hopper. The "OFF" position allows the operator to disable the probe for that hopper only. THE "LOW" and "HIGH" positions allow the operator to select the level of product desired for that hopper.

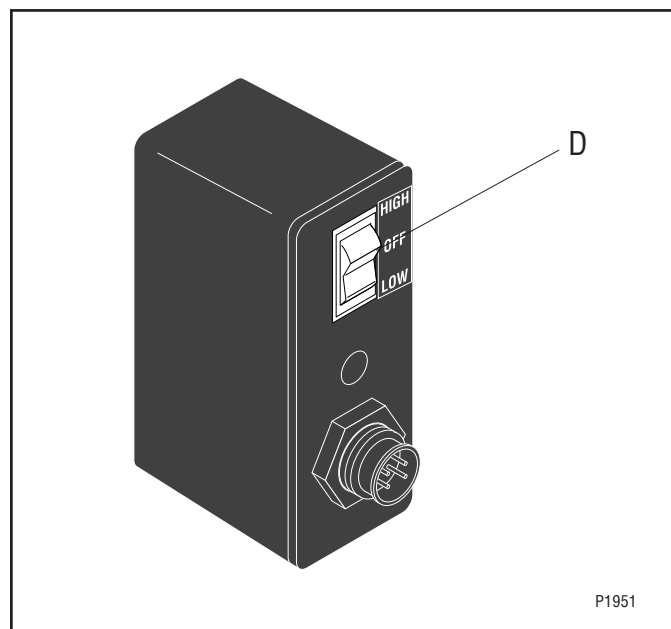

P1951

TROUBLESHOOTING

A troubleshooting guide is provided to suggest probable causes and remedies for the most likely problems encountered. If the problem remains after exhausting the troubleshooting steps, contact the Bunn-O-Matic Technical Service Department.

- Inspection, testing, and repair of electrical equipment should be performed only by qualified service personnel.
- All electronic components have 120 volt ac and low voltage dc potential on their terminals. Shorting of terminals or the application of external voltages may result in board failure.
- Intermittent operation of electronic circuit boards is unlikely. Board failure will normally be permanent. If an intermittent condition is encountered, the cause will likely be a switch contact or a loose connection at a terminal or crimp.
- Solenoid removal requires interrupting the water supply to the valve. Damage may result if solenoids are energized for more than ten minutes without a supply of water.
- The use of two wrenches is recommended whenever plumbing fittings are tightened or loosened. This will help to avoid twists and kinks in the tubing.
- Make certain that all plumbing connections are sealed and electrical connections tight and isolated.
- Keep away from combustibles.

- WARNING** –
- Exercise extreme caution when servicing electrical equipment.
 - Unplug the dispenser when servicing, except when electrical tests are specified.
 - Follow recommended service procedures
 - Replace all protective shields or safety notices

PROBLEM	PROBABLE CAUSE	REMEDY
Product will not dispense	1. No water	Water lines and valves to the dispenser must be open.
	2. No power or incorrect voltage to the dispenser	(A1) Check the outlet for 120 volts on two wire 120 volt dispensers. (A2) Check the outlet for 200 volts or 240 volts ac for two wire 200 volt or 240 volt dispensers. (A3) Check the outlet for 230 volts on two wire 230 volt dispensers. (B) Check circuit breakers or fuses.
	3. Signal cable unplugged	Signal cable must be plugged in.
	4. Hopper is full	Product must not be touching probes to fill.
	5. Fuse and fuse holder	Refer to <i>Service</i> - Fuse and Fuse Holder for test procedures. See page 11

TROUBLESHOOTING (cont.)

PROBLEM

PROBABLE CAUSE

REMEDY

Product will not dispense (cont.)

6. Main ON/OFF switch

Refer to *Service* - Main ON/OFF Switch for testing procedure. See page 12

7. Probe box LOW/OFF/HIGH switches

Refer to *Service* - Probe system. See page 13

8. Circuit board

Refer to *Service* - Circuit Board for testing procedures. See page 10

9. Vacuum switch

Refer to *Service* - Vacuum switch for testing procedures. See page 21

10. Vacuum/Supply pump

Refer to *Service* - Vacuum/Supply pump for testing procedures. See page 19

11. Pump (flavor) start switches

Refer to *Service* - Pump (flavor) start switches for test procedures. See page 14

Incorrect mix ratio

1. No water

Water lines and valves to the dispenser must be open.

2. Needle valve

Refer to *Setup* - Mix Ratio Adjustments for adjustment. See page 4

3. Solenoids

Refer to *Service* - Solenoids for test procedures. See page 16

Motor thermal cutout (motor stops running)

1. Motor overheat

The thermal switch will reset, but requires up to 30 minutes of cooling time. See **NOTE** below

NOTE: This refill unit should not be used to initially fill the hopper. Running the motor for extended periods will trip the thermal switch. The thermal switch will reset, but requires up to 30 minutes of cooling time.

SERVICE

This section provides procedures for testing and replacing various major components used in this dispenser should service become necessary. Refer to *Troubleshooting* for assistance in determining the cause of any problem.

WARNING - Inspection, testing, and repair of electrical equipment should be performed only by qualified service personnel. The dispenser should be unplugged when servicing, except when electrical tests are required and the test procedure specifically states to plug in the dispenser.

COMPONENT ACCESS

WARNING - Disconnect the dispenser from the power source before the removal of any panel or the replacement of any component.

All components are accessible by removing the eight #8-32 screws (five on the front and three on the rear) securing the main housing to the main mounting panel and the removal of the four #8-32 nuts securing the pump/solenoid switch panel to the solenoid mounting bracket. Refer to Fig. 1

Refer to the contents listing for component location.

Contents

Circuit Board	10
Fuse & Fuse Holder	11
Main ON/OFF Switch	12
Probe LOW/OFF/HIGH Switches	13
Pump (Flavor) Start Switches	14
Refill ON/OFF Switches	15
Solenoid	16
Solenoid (Water) Start Switches	17
Test/Operate Switch	18
Vacuum/Supply Pump Assembly	19
Vacuum Switches	21
Piping Diagram	22
Wiring Diagrams	23

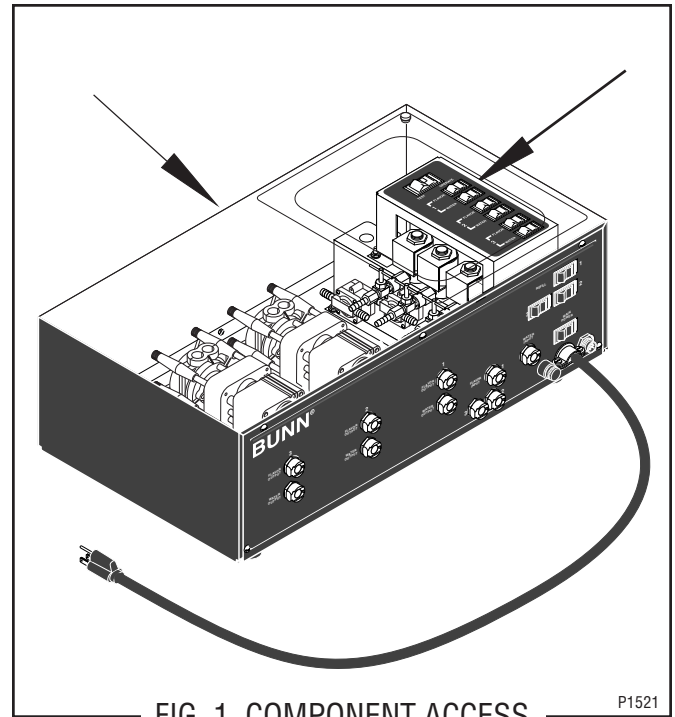

FIG. 1 COMPONENT ACCESS

P1521

SERVICE

CIRCUIT BOARD

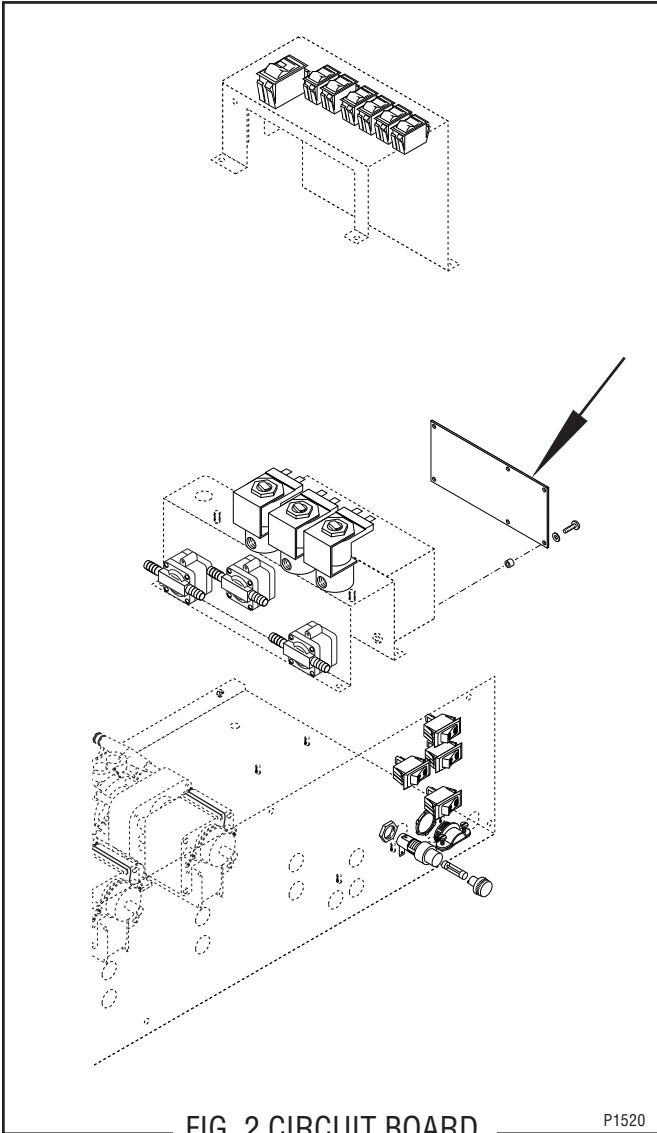

FIG. 2 CIRCUIT BOARD

P1520

Location:

The circuit board is located inside the autofill box, mounted on the right side of the solenoid mounting bracket under the switch panel.

Test Procedure:

1. Disconnect the dispenser from the power source.
2. Disconnect the ten pin plug on the main wiring harness from the connector on the circuit board.
3. Connect the dispenser to the power source. With a voltmeter, check the voltage across the black wire(#3) and the white wire (#6). The indication must be:
 - a) 120 volts ac for two wire 120 volt models.
 - b) 200 to 240 volts ac for two wire 200 or 240 volt models.

- c) 230 volts ac for two wire 230 volt models.
4. Disconnect the dispenser from the power source.

If voltage is present as described, replace the circuit board.

If voltage is not present as described, refer to the *Wiring Diagrams* and check main wiring harness.

Removal and Replacement:

1. Remove the four #8-32 keps nuts securing the switch mounting bracket. Set aside with the wires attached.
2. Remove the circuit board shield and set aside for reassembly.
3. Disconnect the ten pin plug from the main wiring harness to the circuit board.
4. Remove the six #4-40 screws and spacers securing the circuit board to the solenoid mounting bracket. Remove circuit board and discard.
5. Install new circuit board using #4-40 screws and spacers to secure the circuit board to the solenoid mounting bracket. The spacers must be between the solenoid mounting bracket and the circuit board.
6. Place circuit board shield over the circuit board.
7. Install switch panel assembly and secure with four #8-32 keps nuts.
8. Refer to Fig. 3 for circuit board ten pin connector.

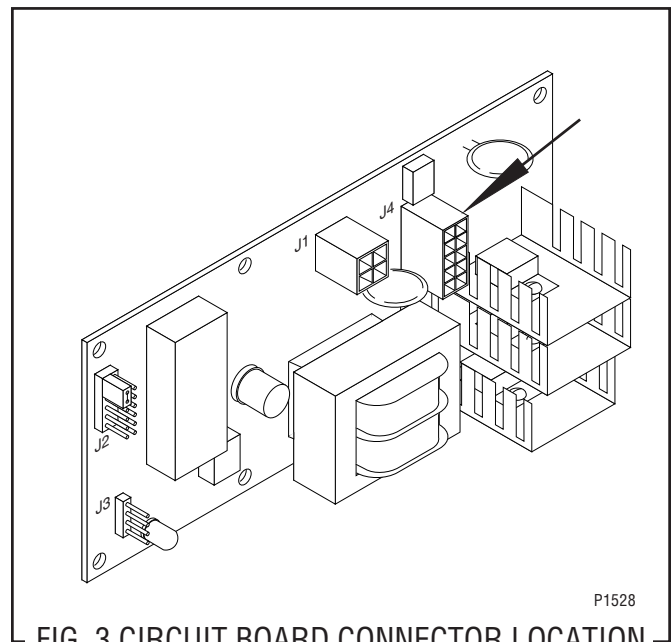
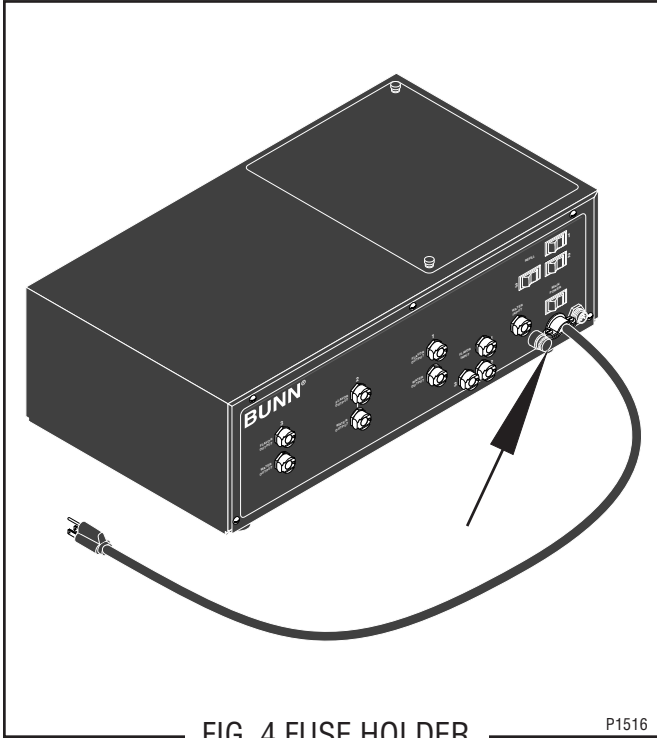

FIG. 3 CIRCUIT BOARD CONNECTOR LOCATION

P1528

SERVICE

FUSE AND FUSE HOLDER



Location:

The fuse holder is located on the lower right front of the autofill box just to the left of the power cord.

Test Procedure:

1. Disconnect the dispenser from the power source.
2. Remove cap and fuse from fuse holder.
3. Remove fuse from the cap.
4. Check for continuity through the fuse.

If continuity is present, reinstall the fuse, the fuse is operating properly.

If continuity is not present, replace the fuse.

Removal and Replacement:

Fuse:

1. Remove the cap from the fuse holder.
2. Remove fuse from the fuse holder and inspect. If blown, discard.
3. Install new 10 amp fuse in the fuse holder.
4. Reinstall fuse holder cap.

Fuse Holder:

1. Disconnect the dispenser from the power source.
2. Disconnect the wires from the rear of the fuse holder.
3. Remove the nut securing the fuse holder to the front of the main mounting panel.
4. Push the fuse holder through the hole in the panel.
5. Install new fuse holder and fuse through the hole in the panel.
6. Secure the fuse holder to the panel.
7. Refer to Fig. 5 and reconnect the wires.

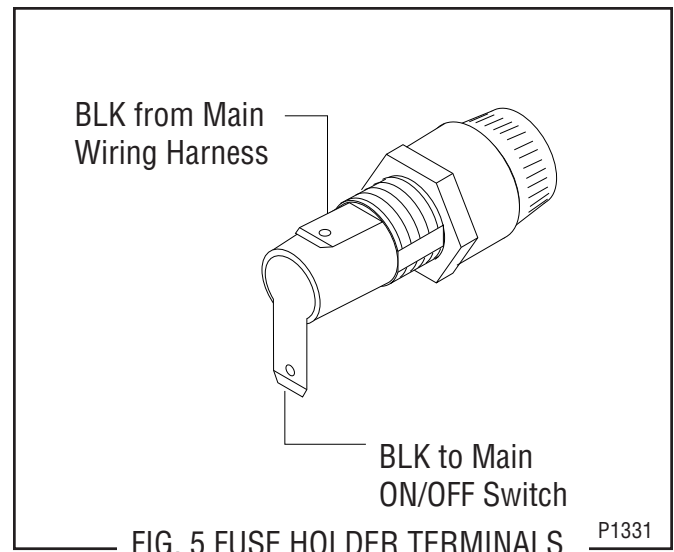

SERVICE (cont.)

MAIN ON/OFF SWITCH

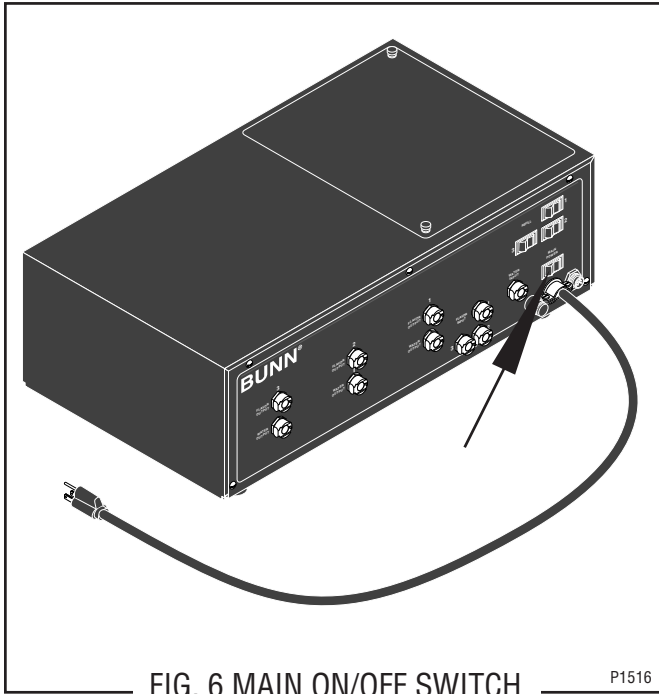

FIG. 6 MAIN ON/OFF SWITCH P1516

Location:

The main ON/OFF switch is located on the lower right front of the autofill box just above the power cord.

Test Procedure:

1. Disconnect the dispenser from the power source.
2. Disconnect the black wire from the fuse holder and the white wire from pump #1.
3. Connect the dispenser to the power source. Check for voltage across the black wire removed from the switch and the white wire removed from pump #1. The indication must be:
 - a) 120 volts ac for 2 wire 120 volt models.
 - b) 200 to 240 volts ac for two wire 200 or 240 volt models.
 - c) 230 volts ac for two wire 230 volt models.
4. Disconnect the dispenser from the power source.

If voltage is present as described, proceed to #5.
If voltage is not present as described, refer to the *Wiring Diagrams* and check the dispenser wiring harness.

5. Check for continuity across the switch terminals with the switch in the "ON" position. Continuity must not be present when the switch is in the "OFF" position.

If continuity is present as described, reconnect the wires to the switch terminals.

If continuity is not present as described, replace the switch.

Removal and Replacement:

1. Remove the wires from the switch terminals.
2. Compress the clips inside the autofill box and gently push the switch through the opening
3. Push the new switch into the opening and spread the clips to hold switch in the autofill box.
4. Refer to Fig. 7 when reconnecting the wires.

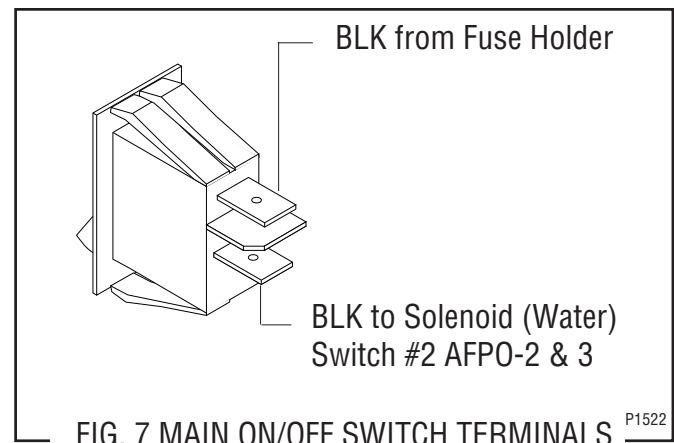

FIG. 7 MAIN ON/OFF SWITCH TERMINALS P1522

SERVICE (cont.)

PROBE SYSTEM

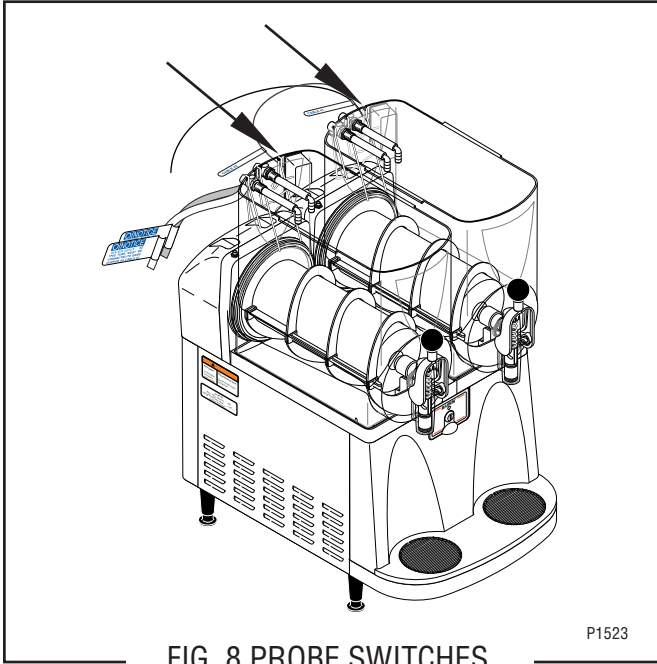

FIG. 8 PROBE SWITCHES

P1523

Location

The probe switches are located on the rear of each hopper, mounted in the probe housing cover.

Test Procedure

Probe System

1. Disconnect the dispenser from the power source.
2. With the probe boxes connected to the signal cable, remove connector from refill box.
3. Place the switch on the probe box in the “HIGH” position.
4. Check resistance across pins as shown in Fig. 9.

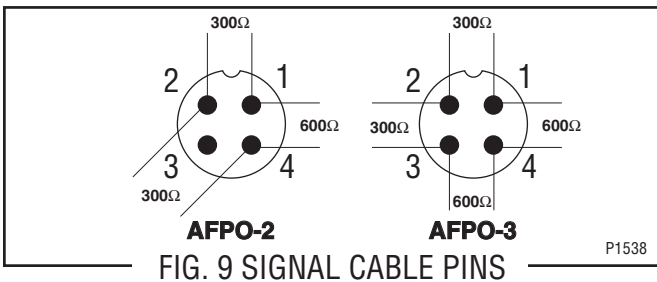

FIG. 9 SIGNAL CABLE PINS

P1538

5. With the probe box switch in “LOW” position check the resistance across the signal cable pins, see Fig. 9.
6. If readings match values indicated, the probe system is functioning properly. If not, check the probe boxes.

Probe Boxes:

1. Disconnect the signal cable from the probe boxes.
2. Remove probe box from CDS hopper.
3. Place the switch on the probe box in the “HIGH” position.
4. Check the resistance across the box cable pins, see Fig. 10.

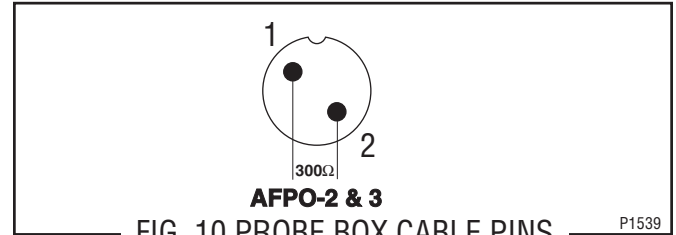

FIG. 10 PROBE BOX CABLE PINS

P1539

5. With the probe box switch in the “LOW” position check the resistance across the pins, refer to Fig. 10.
6. If readings match the values indicated, the probe system is functioning properly.

Switch Removal and Replacement:

1. Remove the #6 thread cutting screw securing the probe housing cover to the probe housing.
2. Remove the wires from the switch terminals.
3. Compress the clips inside the probe box and gently push the switch through the opening
4. Push the new switch into the opening and spread the clips to hold switch in the autofill box.
5. Refer to Fig. 11 when reconnecting the wires.

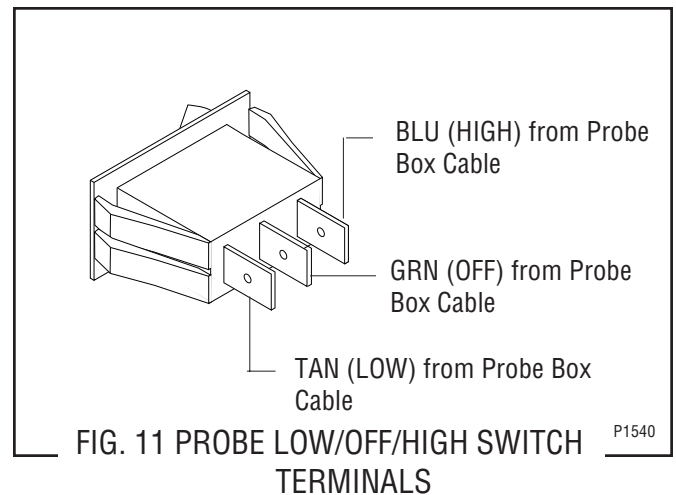

FIG. 11 PROBE LOW/OFF/HIGH SWITCH TERMINALS

P1540

SERVICE (cont.)

PUMP (FLAVOR) ON/OFF SWITCHES

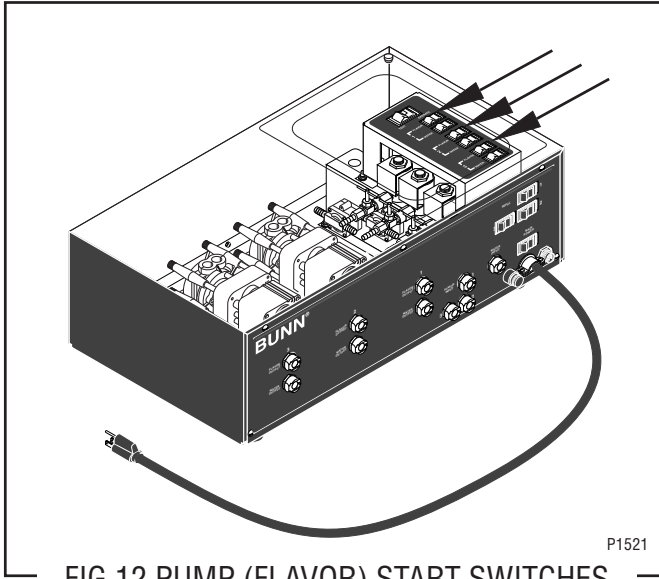

FIG.12 PUMP (FLAVOR) START SWITCHES

Location:

The pump (flavor) START switches are located on the switch mounting plate inside the autofill box on the right side.

Test Procedure:

1. Disconnect the dispenser from the power source.
2. Disconnect the wires from the switch to be tested.
3. Check for continuity across the terminals on the switch when it is held in the on position. Continuity must not be present across these terminals in the released position.

If continuity is present as described, reconnect the wires to the switch.

If continuity is not present as described, replace the switch.

Removal and Replacement:

1. Disconnect the dispenser from the power source.
2. Remove the wires from the switch terminals.

3. Compress the clips inside the autofill box and gently push the switch through the opening.
4. Push the new switch into the opening and spread the clips to hold switch in the autofill box.
5. Refer to Fig. 13 when reconnecting the wires.

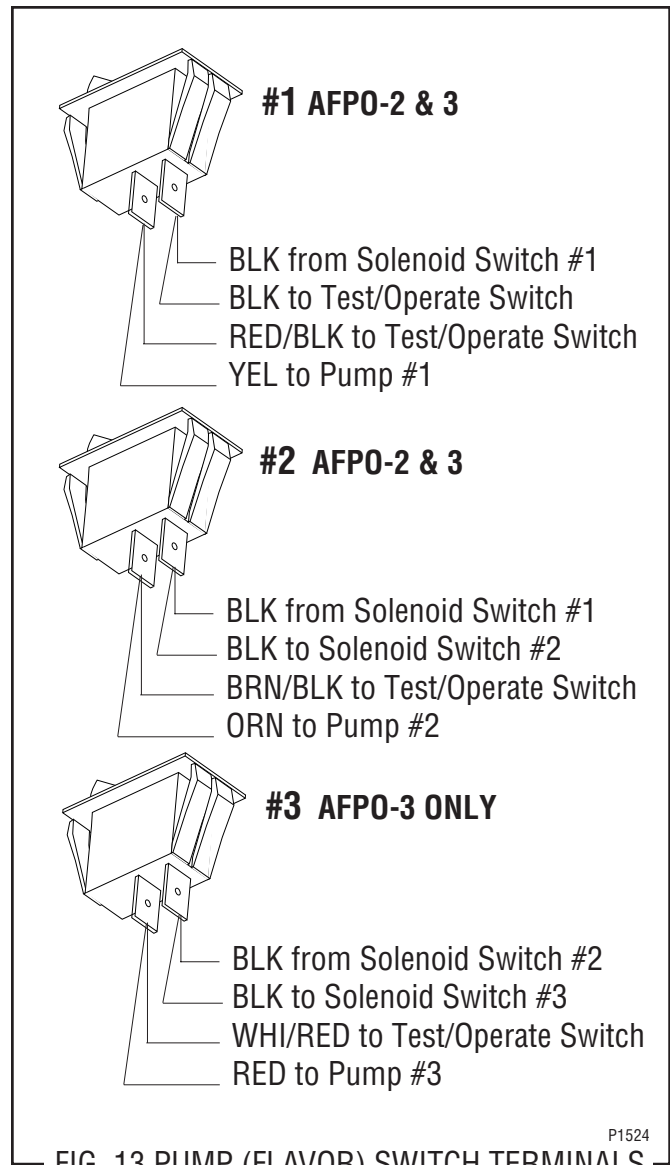

FIG. 13 PUMP (FLAVOR) SWITCH TERMINALS

SERVICE (cont.)

REFILL SWITCHES

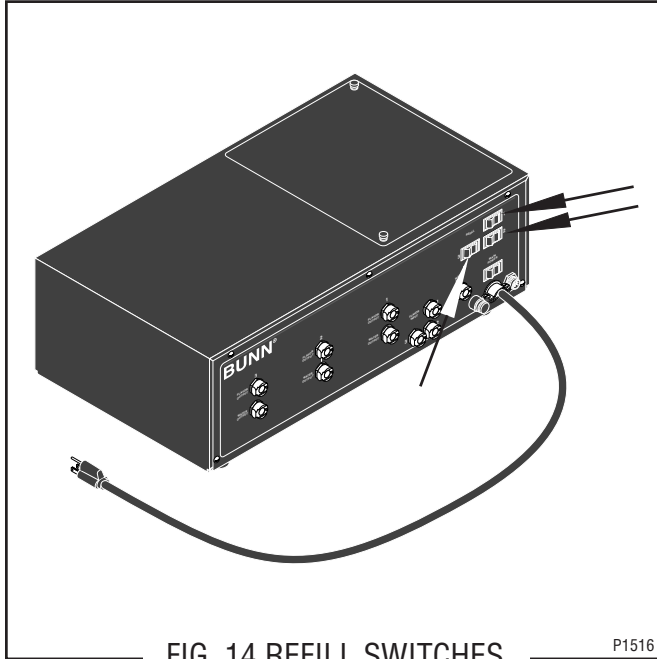

FIG. 14 REFILL SWITCHES

P1516

Location:

The refill switches are located on the upper right front of the autofill box.

Test Procedures:

1. Disconnect the dispenser from the power source.
2. Disconnect the two white/red, brown/black or red/black wires from the switch terminals.
3. Connect the dispenser to the power source. Check for voltage across the white/red, brown/black or red/black wires from the test/operate switch and the white wire on solenoid #2 or #3. The indication must be:
 - a) 120 volts ac for two wire 120 volt models
 - b) 200 to 240 volts ac for two wire 200 or 240 volt models.
 - c) 230 volts ac for two wire 230 volt models.
4. Disconnect the dispenser from the power source.

If voltage is present as described, proceed to #5.

If voltage is not present as described, refer to the *Wiring Diagrams* and check dispenser wiring harness.

5. Check for continuity across the switch terminals with the switch in the "ON" position. Continuity must not be present when the switch is in the "OFF" position.

If continuity is present as described, reconnect the wires to the switch terminals.

If continuity is not present as described, replace the switch.

Removal and Replacement:

1. Remove the wires from the switch terminals.
2. Compress the clips inside the autofill box and gently push the switch through the opening in the front of autofill box.
3. Push the new switch into the opening and spread the clips to hold switch in the autofill box.
4. Refer to Fig. 15 when reconnecting the wires.

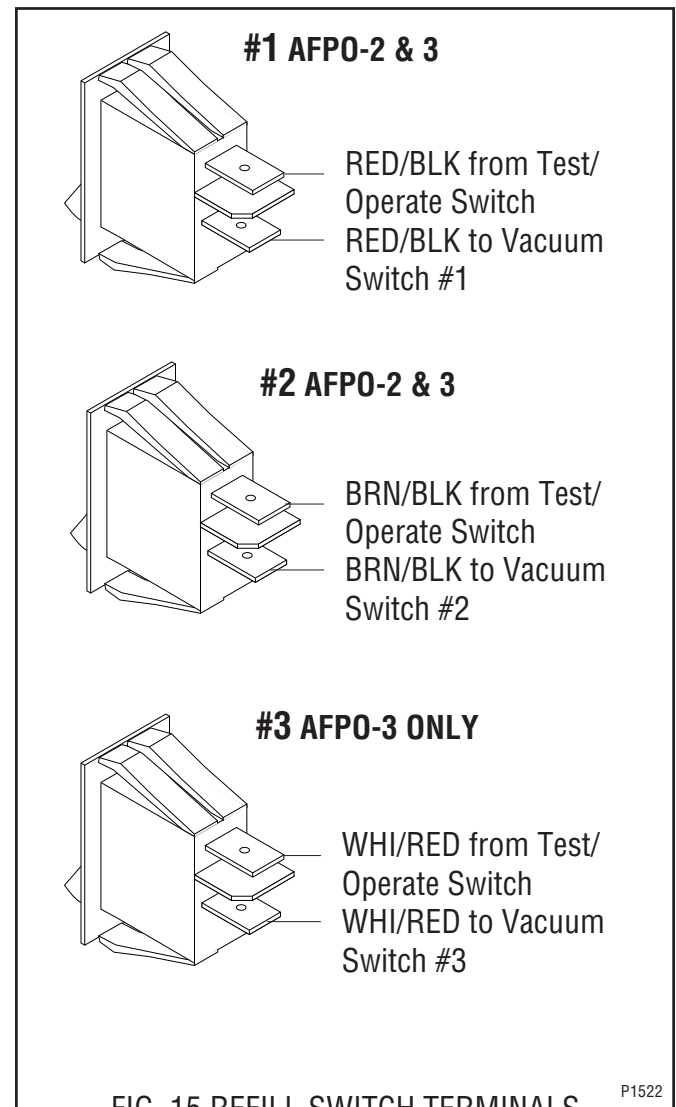

FIG. 15 REFILL SWITCH TERMINALS

P1522

SERVICE (cont.)

SOLENOIDS

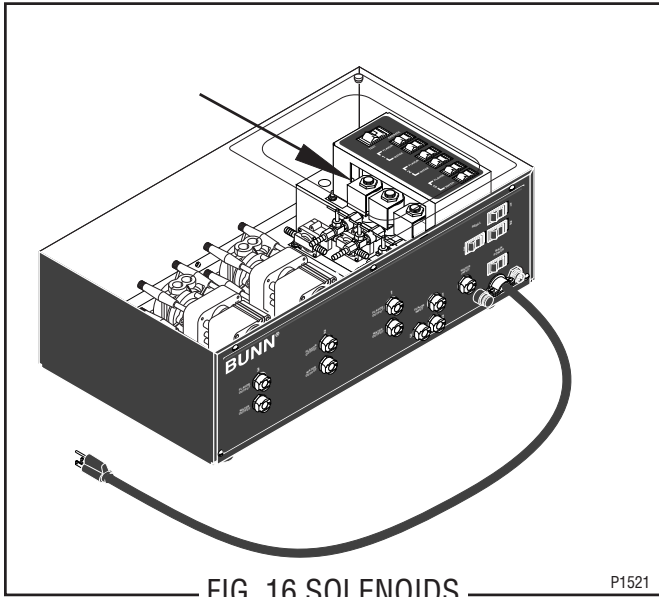

FIG. 16 SOLENOIDS

P1521

Location:

The solenoids are located inside the autofill box.

Test Procedure:

1. Disconnect the dispenser from the power source.
2. Disconnect the white/violet, violet or blue wire and the white wire from the solenoid.
3. Connect the dispenser to the power source. Press the solenoid (water) switch, and with a voltmeter, check the voltage between the white wire, and either the blue, violet, or white/violet wire. The indication must be:
 - a) 120 volts ac for two wire 120 volt models.
 - b) 200 to 240 volts ac for two wire 200 or 240 volt models.
 - c) 230 volts ac for two wire 230 volt models.
4. Disconnect the dispenser from the power source.

If voltage is present as described, proceed to #5.
If voltage is not present as described, refer to the *Wiring Diagrams* and check dispenser wiring harness.

5. Check for continuity across the solenoid valve coil terminals.

If continuity is present as described, refer to Fig. 17 and reconnect the wires to the solenoid.
If continuity is not present as described, replace the solenoid valve.

6. Check the solenoid valve for coil action. Connect the dispenser to the power source. Press the solenoid (water) switch and listen carefully in the vicinity of the solenoid valve for a "clicking" sound as the coil magnet attracts.
7. Disconnect the dispenser from the power source.

If the sound is heard as described and water will not pass through the solenoid valve, there may be a blockage in the water inlet before the solenoid valve or, the solenoid valve may require inspection for wear, and removal of waterborne particles.

If the sound is not heard as described, rebuild or replace the solenoid valve.

Solenoid Valve Repair:

1. Remove the wires from the solenoid valve to be repaired.
2. Turn off the water supply to the dispenser.
3. Remove the nut securing solenoid valve coil to the base.
4. Remove guide, washer, o-ring, plunger/spring and inspect for wear. Replace parts as required.
5. Install new o-ring in the solenoid valve base.
6. Install plunger/spring in the guide with spring to the bottom of the guide.
7. Install guide with the plunger/spring into the solenoid valve base.
8. Install washer on guide.
9. Install coil with retainer on guide and secure with nut.
10. Refer to Fig. 17 and reconnect the wires.

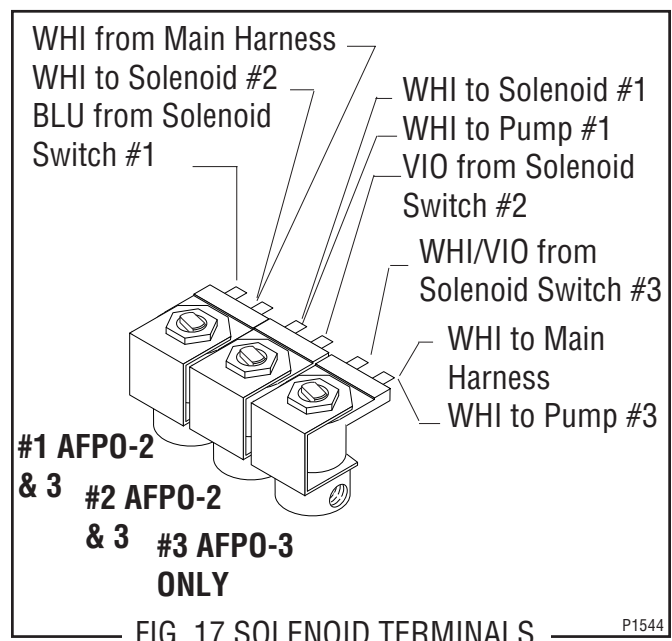
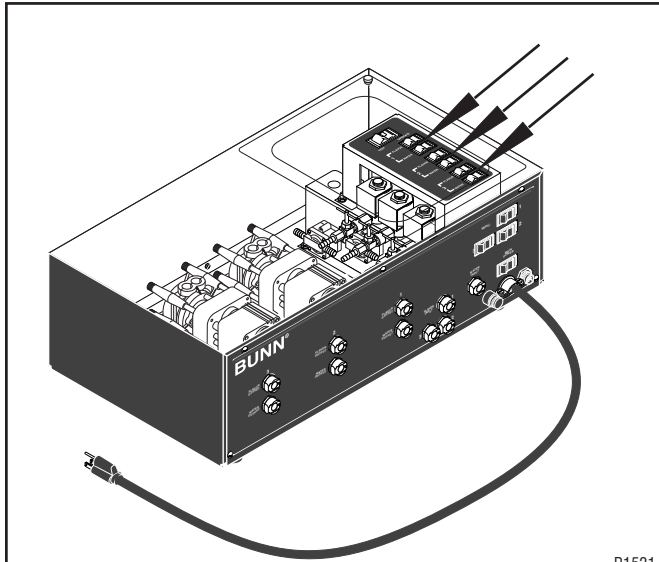

FIG. 17 SOLENOID TERMINALS

P1544

SERVICE (cont.)

SOLENOID (WATER) ON/OFF SWITCHES



P1521

FIG.18 SOLENOID (WATER) ON/OFF SWITCHES

Location:

The solenoid (water) ON/OFF switches are located on the switch mounting plate inside the autofill box on the right side.

Test Procedure:

1. Disconnect the dispenser from the power source.
2. Disconnect the wires from the switch to be tested.
3. Check for continuity across the terminals on the switch when it is held in the on position. Continuity must not be present across these terminals in the released position.

If continuity is present as described, refer to Fig. 19 and reconnect the wires to the switch.

If continuity is not present as described, replace the switch.

Removal and Replacement:

1. Remove the wires from the switch terminals.
2. Compress the clips inside the autofill box and gently push the switch through the opening.
3. Push the new switch into the opening and spread the clips to hold switch in the autofill box.
4. Refer to Fig. 19 when reconnecting the wires.

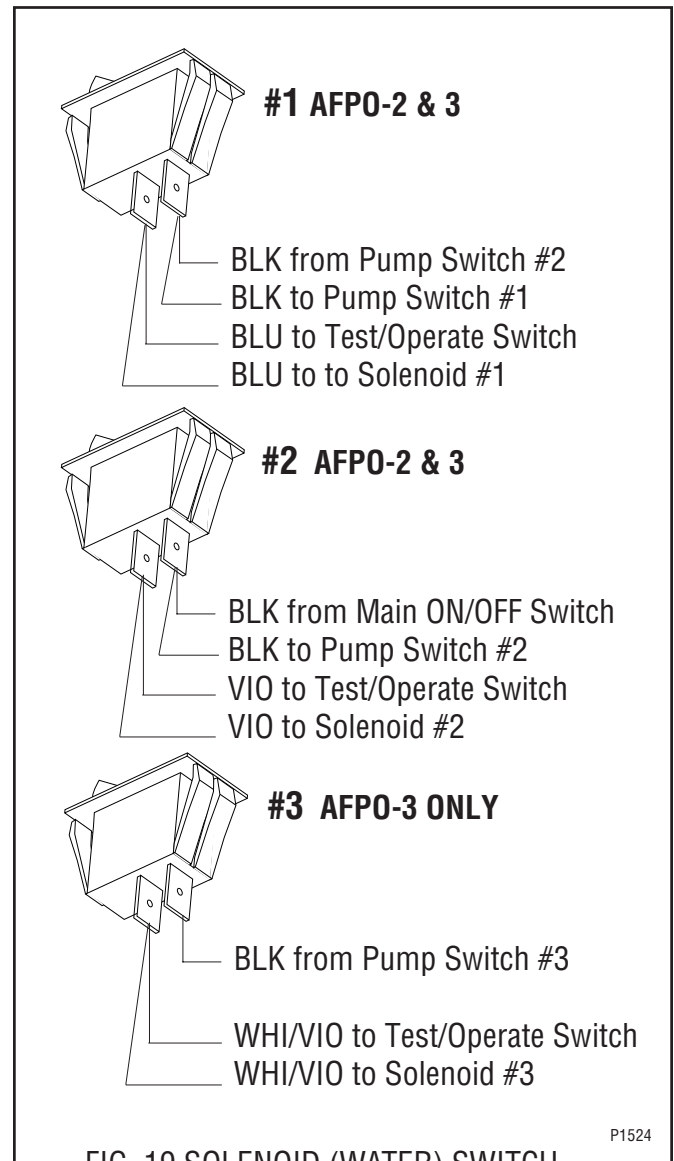

P1524

FIG. 19 SOLENOID (WATER) SWITCH TERMINALS

SERVICE (cont.)

TEST/OPERATE ON/OFF SWITCH

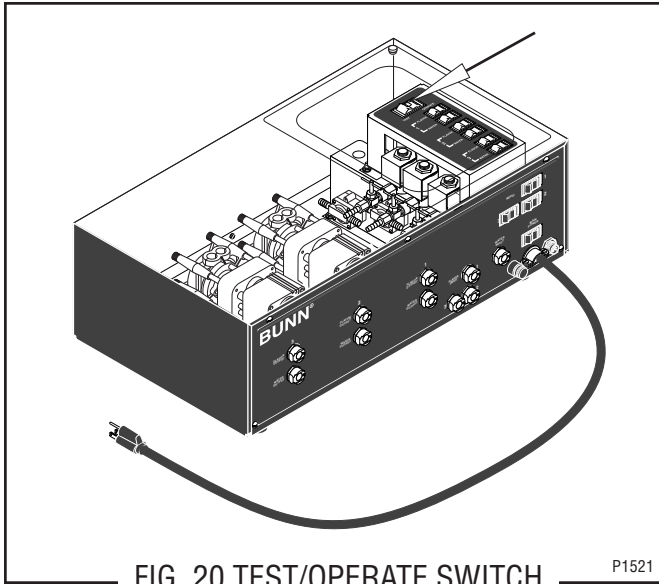

FIG. 20 TEST/OPERATE SWITCH

Location

The test/operate switch is located inside the autofill box on the right side.

Test Procedures:

1. Disconnect the dispenser from the power source.
2. Remove the black wire from the top center switch terminal.
3. Connect the dispenser to the power source. With a voltmeter, check the voltage across the black wire removed from the test/operate switch and the white wire from one of the solenoids. The indication must be:

- a) 120 volts ac for two wire 120 volt models.
 - b) 200 to 240 volts ac for two wire 200 or 240 volt models.
 - c) 230 volts ac for two wire 230 volt models.
5. Disconnect the dispenser from the power source.

If voltage is present as described, proceed to #6.
If voltage is not present as described, refer to the *Wiring Diagrams* and check the wiring harness.

6. Disconnect the wires from the left and center terminals.
7. Check for continuity across the left and center terminals in rows one, two, three and four with the switch in the “operate” position. Continuity should not be present across the left and center terminals with the switch in the “center” or “Test” position.

If continuity is present as described, replace the wires.
The switch is operating properly.

If continuity is not present as described, replace the switch.

Removal and Replacement:

1. Disconnect the dispenser from the power source.
2. Remove the wires from the switch terminals.
3. Compress the clips inside on the back of the switch panel and gently push the switch through the opening.
4. Push the new switch into the opening and spread the clips to hold the switch in the switch panel.
5. Refer to FIG. 21 when reconnecting the wires.

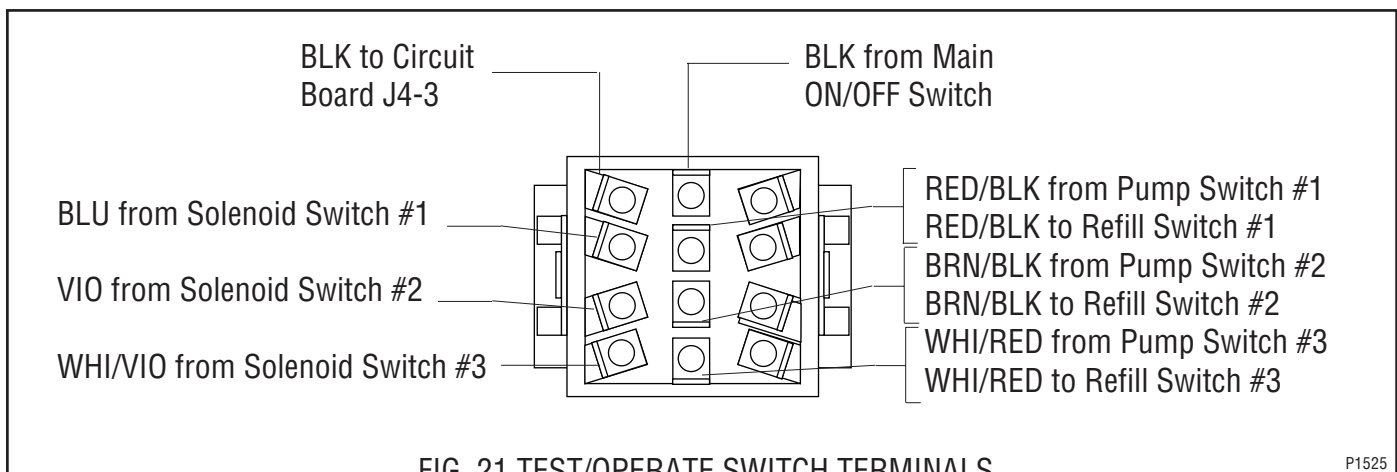

FIG. 21 TEST/OPERATE SWITCH TERMINALS

P1525

SERVICE (cont.)

VACUUM/SUPPLY PUMP ASSEMBLY

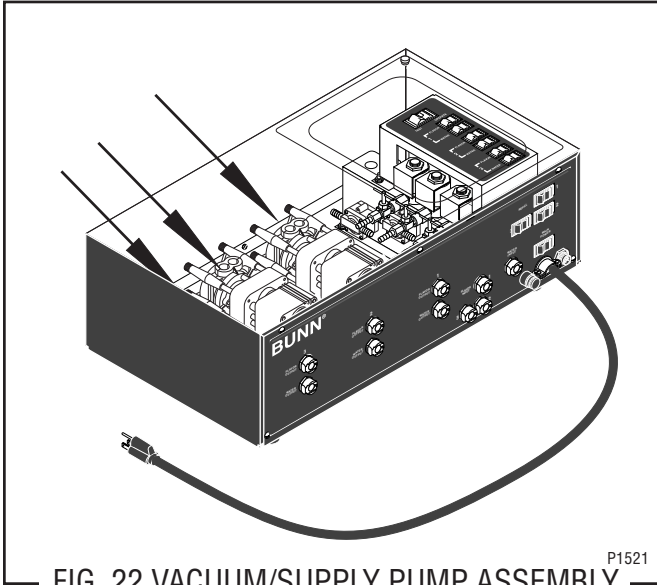

FIG. 22 VACUUM/SUPPLY PUMP ASSEMBLY

Location:

The vacuum/supply pumps are located inside the autofill box.

Test Procedure:

1. Disconnect the dispenser from the power source.
2. Disconnect the white wire from the pump lead and the yellow, orange or red wire from the other lead.
3. Connect the dispenser to the power source. With a voltmeter, check the voltage across the white wire and yellow, orange or red wire. Push the pump (flavor) switch for the pump to be tested. The indication must be :

- a) 120 volts ac for two wire 120 volt models.
 - b) 200 to 240 volts ac for two wire 200 or 240 volt models.
 - c) 230 volts ac for two wire 230 volt models.
4. Disconnect dispenser from the power source.

If voltage is present as described, replace the pump. If voltage is not present as described, refer to the *Wiring Diagrams* and check main wiring harness.

Pump Motor Removal and Replacement:

NOTE: Do not disconnect or damage tubing. Tubing is not replaced when pump is replaced.

1. Disconnect the pump motor leads.
2. Remove the four thumb screws securing the pump head to the pump body.
3. Remove the two #8-32 keps nuts securing the pump motor/bracket assembly to the refill unit.
4. Remove the two #6-32 screws securing the pump motor to its mounting bracket.
5. Reattach this bracket to the new motor, and reinstall the assembly in the refill unit.
6. Reattach the pump head to the rear of the pump motor with the four thumbscrews.
7. Reconnect the pump motor leads. Refer to Fig. 23 to reconnect the wires.

Pump Removal and Replacement:

NOTE: Do not disconnect or damage tubing. Tubing is not replaced when pump is replaced.

1. Remove the four thumb screws securing the pump head to the pump body.

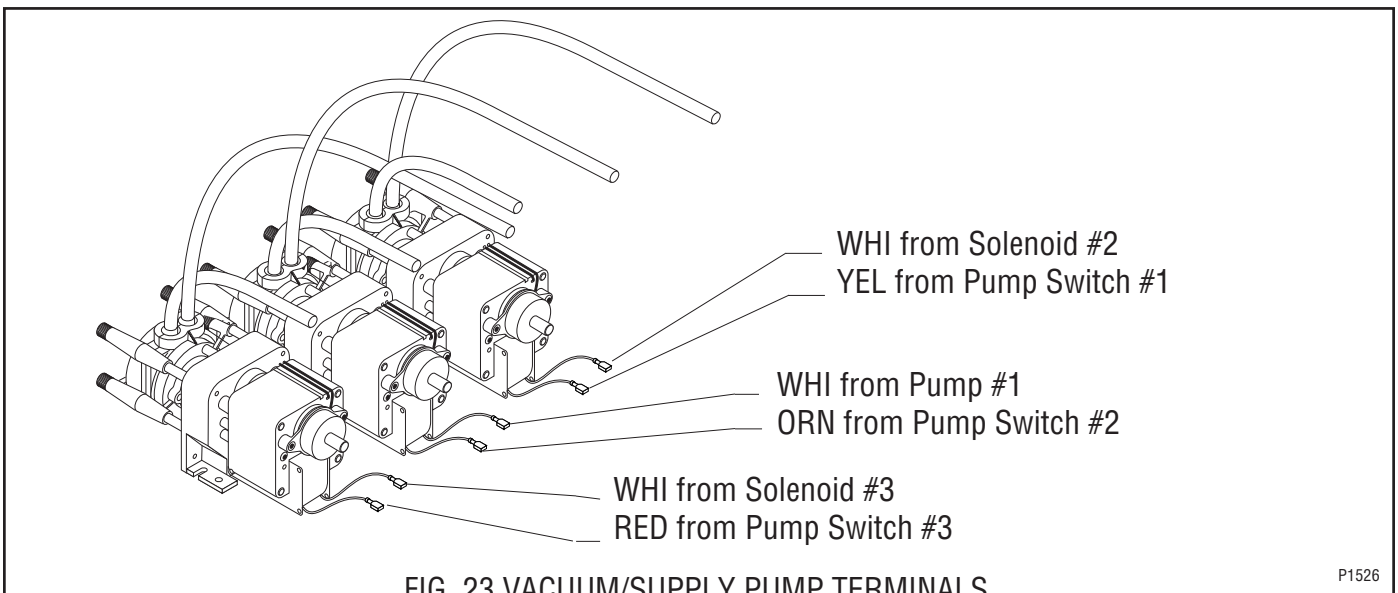

FIG. 23 VACUUM/SUPPLY PUMP TERMINALS

SERVICE (cont.)

VACUUM/SUPPLY PUMP TUBE INSTALLATION

2. Separate the two halves of the pump and carefully remove the tubing from within.
3. Hold the new pump head as shown in Fig. 24, with rollers in the 2, 6, and 10 o'clock positions.
4. Reinstall tubing in the new pump head by wrapping the tubing around the rollers as shown in Fig. 24.
5. Insert the slot of the tubing key (supplied), as shown in Fig. 24, on the rotor so the bottom edge of the key is pressing the tubing into the pump head cavity as shown in Fig. 25.
6. Hold the tubing and rotor in the pump head and remove key carefully.
7. Squeeze the pump body and pump heads together simultaneously until pump body and pump head are touching on all sides. Be careful not to pinch the tubing between the pump body and the pump head.
8. Place the new pump body on the rotor shaft.
9. Replace the four thumbscrews to secure the pump to the motor assembly. Finger-tighten only.

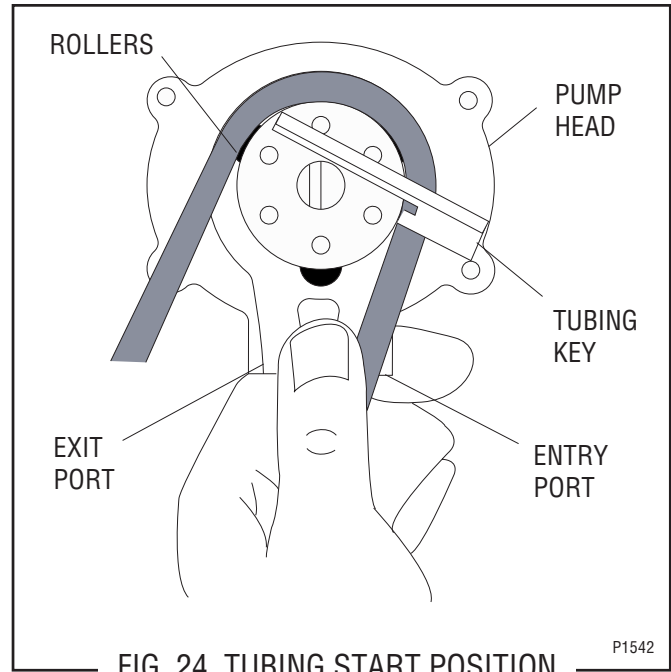

FIG. 24 TUBING START POSITION

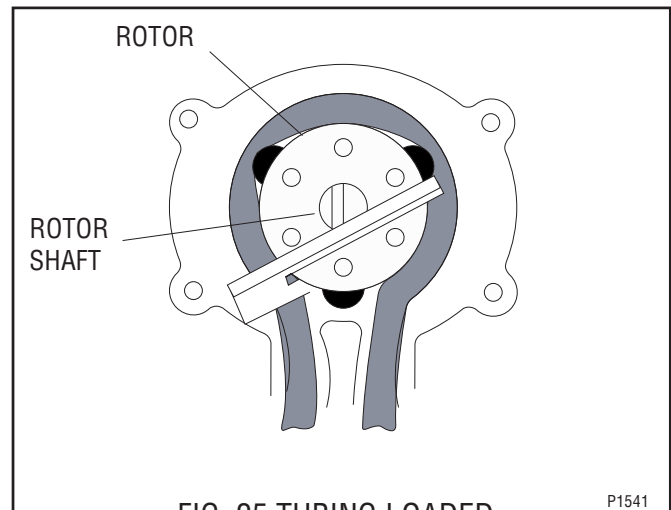

FIG. 25 TUBING LOADED

SERVICE (cont.)

VACUUM SWITCHES

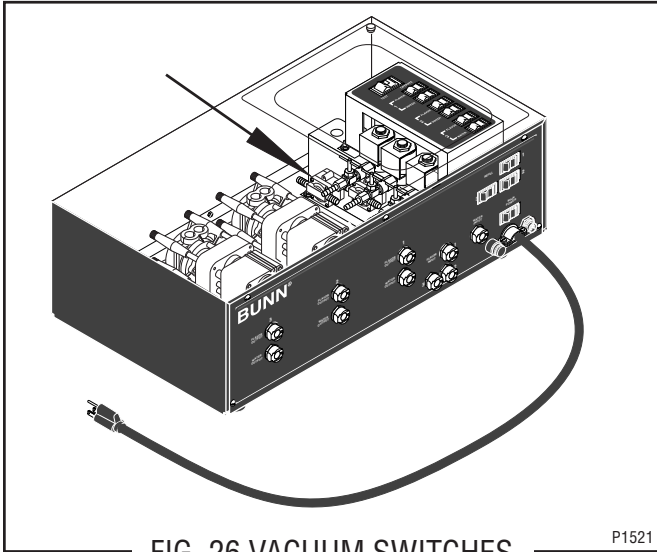

FIG. 26 VACUUM SWITCHES

P1521

Location:

The vacuum switches are located inside autofill box, mounted on the left side of the solenoid mounting bracket just below the needle valves.

Test Procedure:

1. Disconnect the dispenser from the power source.
2. Disconnect flavor input lines.
3. Disconnect white/red, red/black or the brown/black wires on the vacuum switch.
4. Check for continuity across the switch leads.

If continuity is not present as described, the vacuum switch is operating properly.

If continuity is present as described, without a vacuum generated by an empty product concentrate, replace the vacuum switch.

Removal and Replacement:

1. Disconnect dispenser from the power source.
2. Removal of the two #8-32 keps nuts securing the pump/motor assembly nearest the vacuum switches is required to access the lower vacuum switch.
3. Disconnect the input tubes from the vacuum switch to be replaced.
4. Disconnect the wires on the vacuum switch to be removed.
5. Remove the two #4-40 screws securing the vacuum switch to the solenoid bracket. Remove and discard switch.
6. Using two #4-40 screws secure the new vacuum switch to the solenoid bracket.
7. Refer to Fig. 27 and reconnect the wires.
8. Connect the input tubes to the new vacuum switch.
9. Restore the pump/motor assembly to its normal mounting position using the two #8-32 keps nuts.

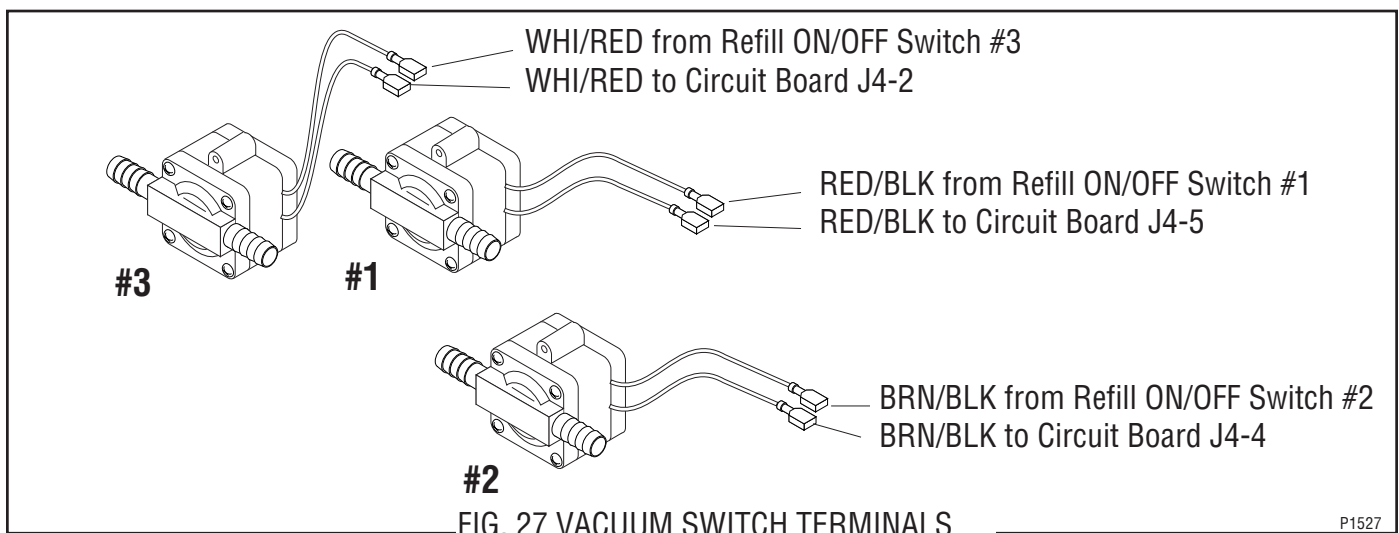
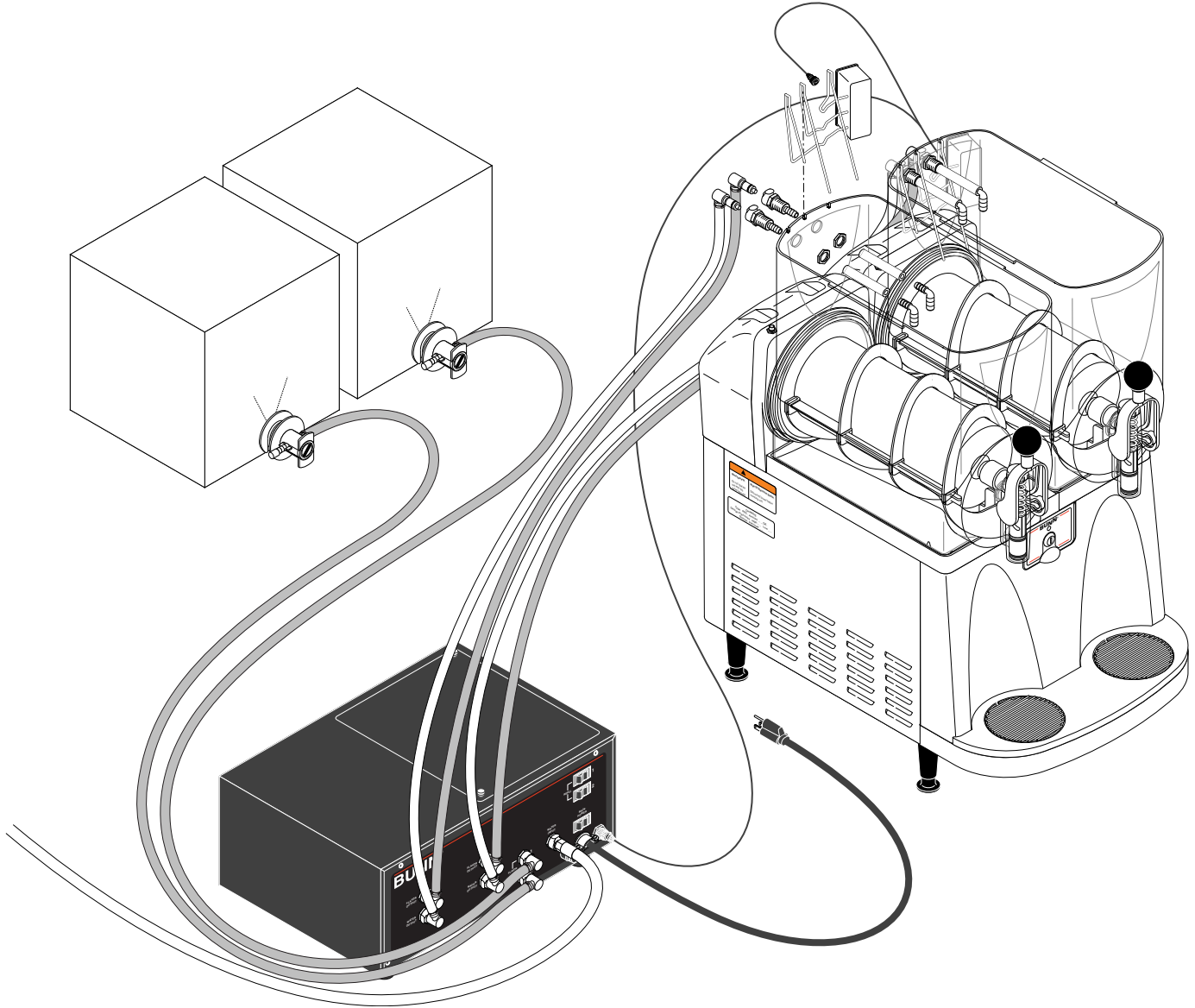

FIG. 27 VACUUM SWITCH TERMINALS

P1527

PIPING DIAGRAM (AFPO-2)

The only difference between the AFPO-2/3 and AFPO-2/3 SL is the SL models have a water output line and a flavor output line for each product. This allows the water and flavor to be mixed in the CDS hoppers. Refer to the illustration below when connecting the lines.



SCHEMATIC WIRING DIAGRAM AFPO-2

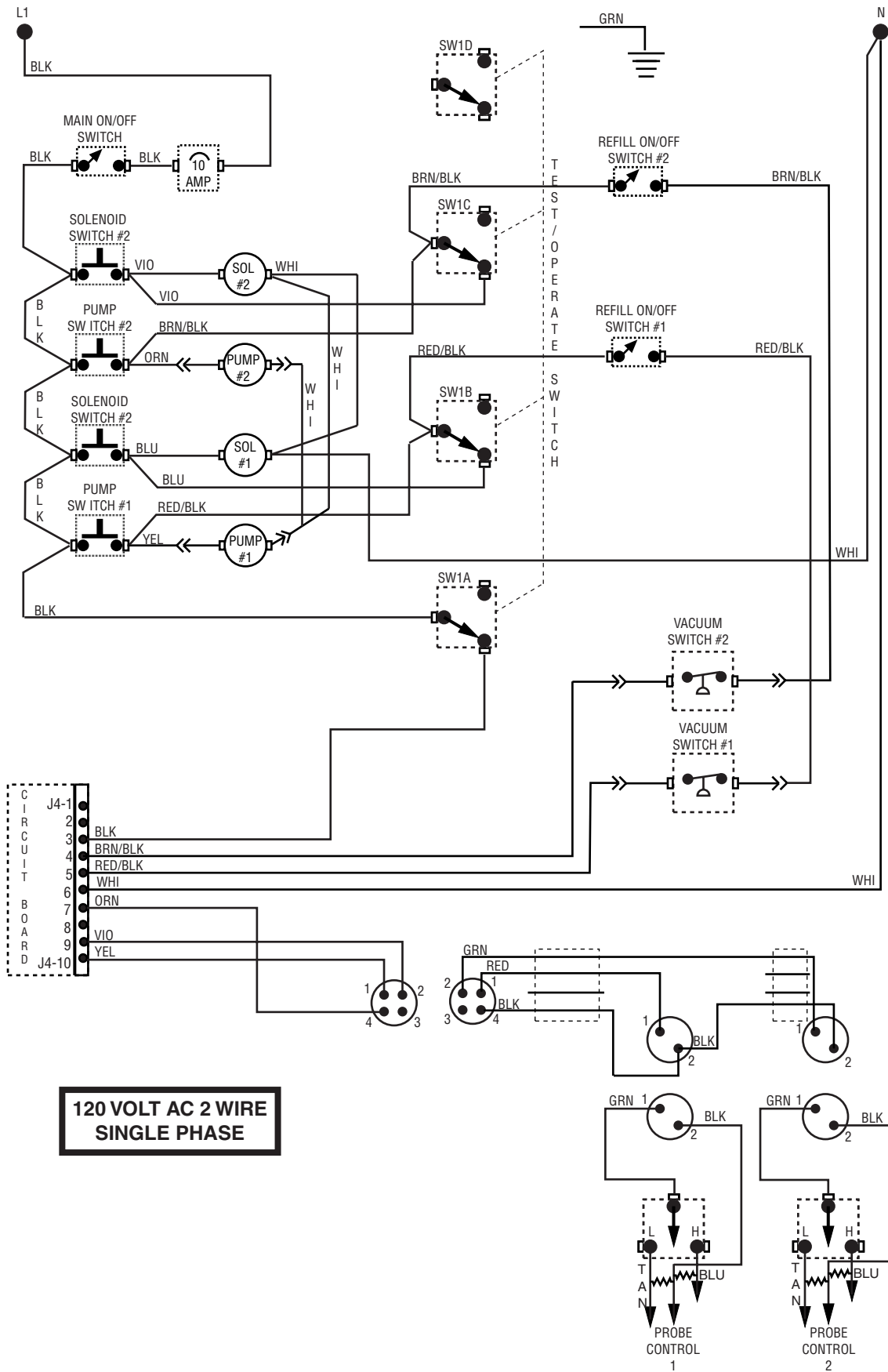

**120 VOLT AC 2 WIRE
SINGLE PHASE**

SCHEMATIC WIRING DIAGRAM AFPO-3

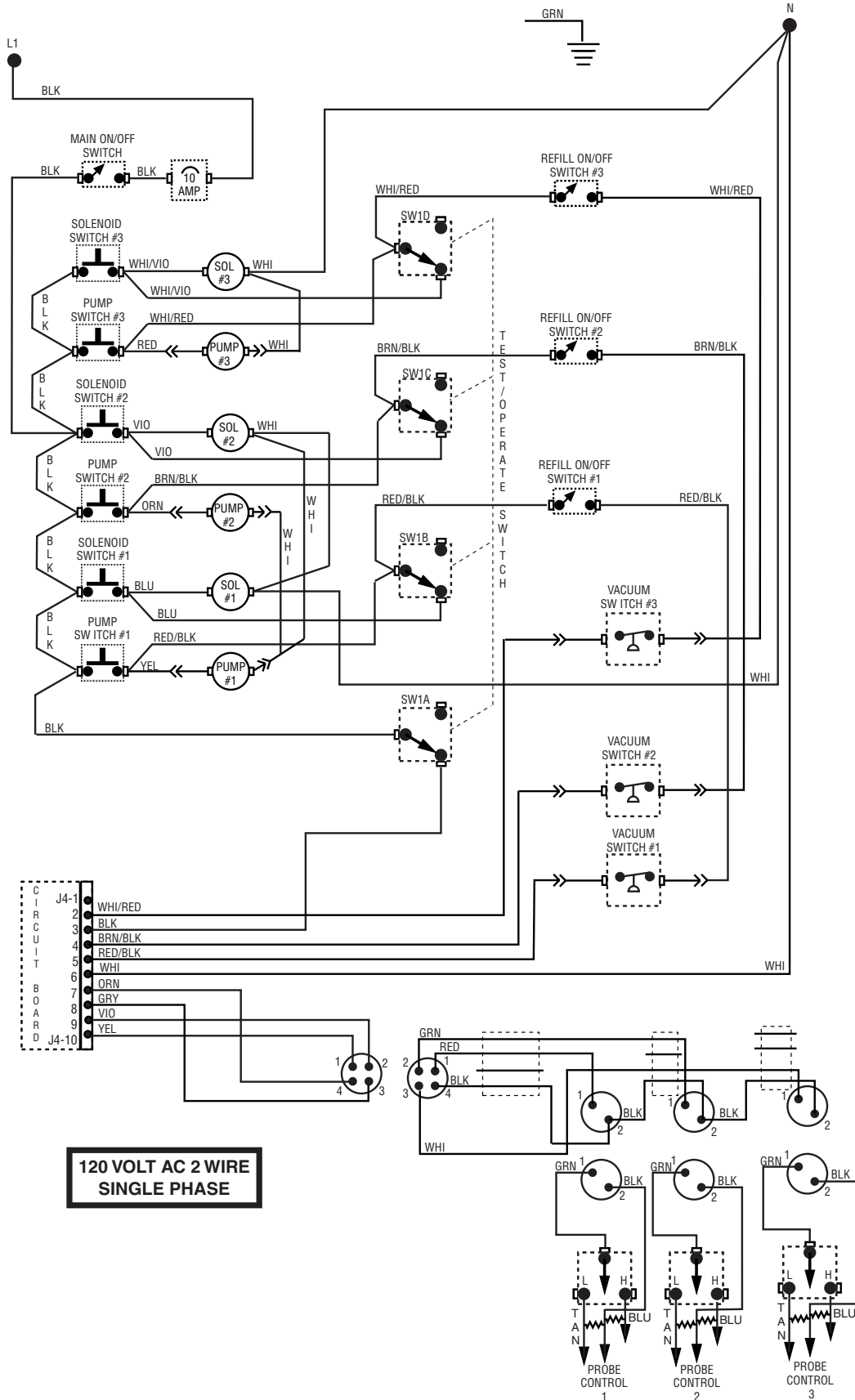

**120 VOLT AC 2 WIRE
SINGLE PHASE**

SCHEMATIC WIRING DIAGRAM AFPOA-2

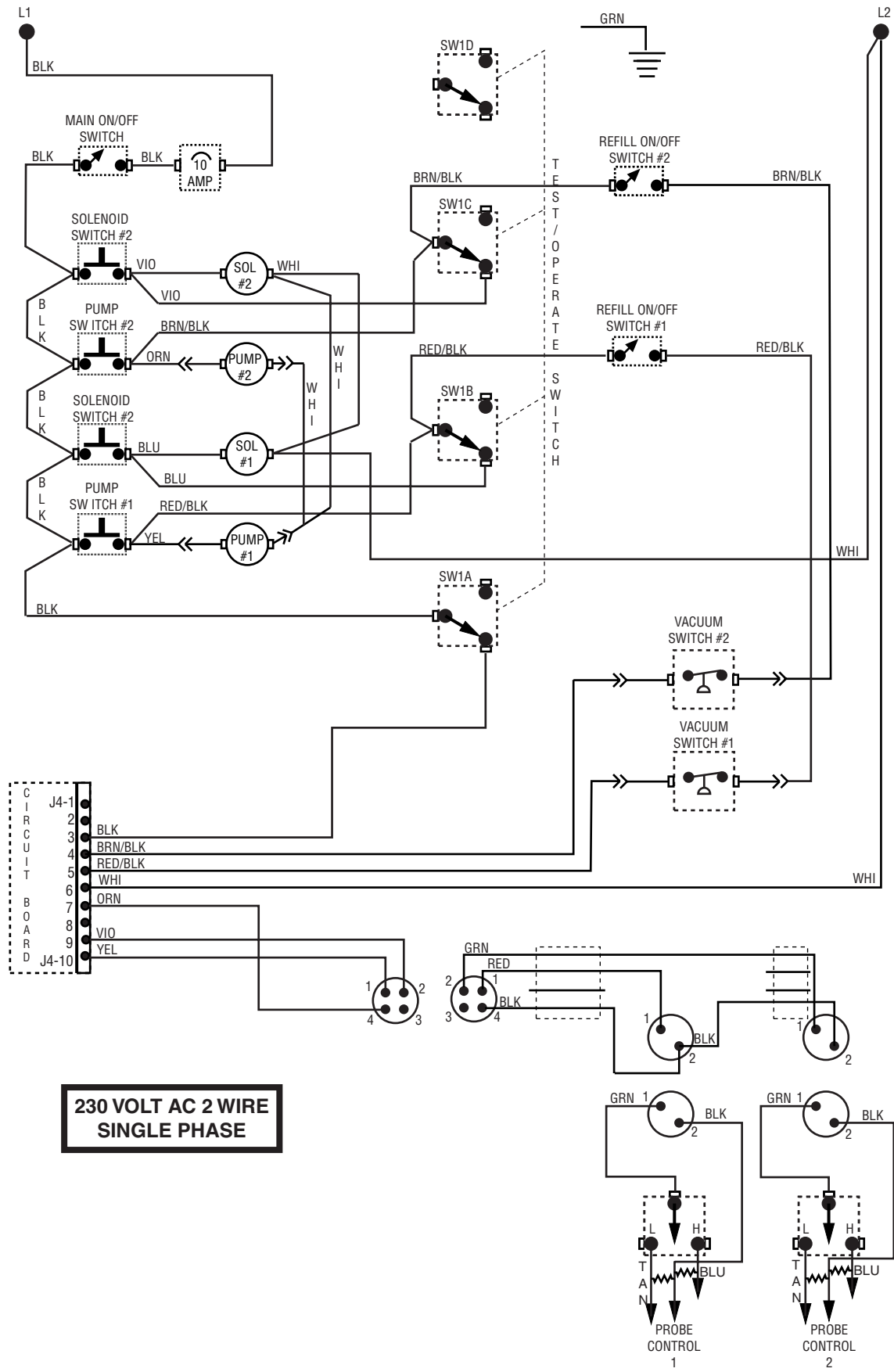

**230 VOLT AC 2 WIRE
SINGLE PHASE**